

## KEY TO BASIC CIRCUIT DIAGRAM 2¼ LITRE 4-CYLINDER DIESEL MODELS, R.H. AND L.H. STEERING, NEGATIVE EARTH

1 Heater plugs	26 Warning light, charge
2 Horn	27 Warning light, oil pressure
3 Instrument panel illumination	28 Warning light, low fuel level
4 Instrument panel illumination	29 Voltage stabiliser unit, fuel gauge and water temperature gauge
5 Tail lamp, LH	30 Switch, stop lamps
6 Tail lamp, RH	31 Switch, windscreen wiper
7 Side lamp, RH	32 Warning light, RH indicator
8 Side lamp, LH	33 Warning light, LH indicator
9 Headlamp, RH dipped beam	34 Alternator 16 ACR
10 Headlamp, LH dipped beam	35 Fuel gauge
11 Headlamp, LH main beam	36 Water temperature gauge
12 Headlamp, RH main beam	37 Wiper motor
13 Warning light, headlamp main beam	38 Switch, oil pressure
14 Battery	39 Fuel tank unit
15 Warning light and resistor, heater plugs	40 Transmitter, water temperature
16 Inspection sockets	41 Stop lamp, LH
17 Switch, horn	42 Stop lamp, RH
18 Switch, panel light	43 Windscreen washer motor (when fitted)
19 Solenoid, starter motor	44 Indicator, front RH
20 Switch, starter-heater plugs	45 Indicator, rear RH
21 Switch, lights	46 Indicator, rear LH
22 Switch, headlamp dip and flash	47 Indicator, front LH
23 Fuses, 1 to 8, 35 amp	
24 Indicator unit, flasher	
25 Switch, indicators	

### Key to cable colours

B	Black	R	Red
G	Green	U	Blue
L	Light	W	White
N	Brown	Y	Yellow
P	Purple		

The last letter of a colour code denotes the tracer colour.

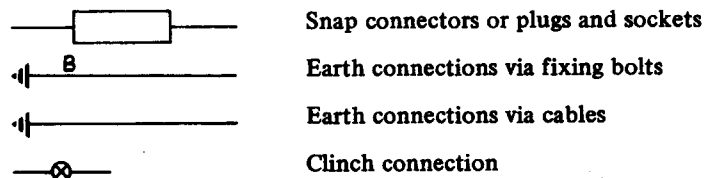

### CIRCUIT DIAGRAM 2¼ AND 2.6 LITRE PETROL MODELS, R.H. AND L.H. STEERING, NEGATIVE EARTH INCLUDING FOG LAMPS AND REAR FOG-GUARD LAMPS

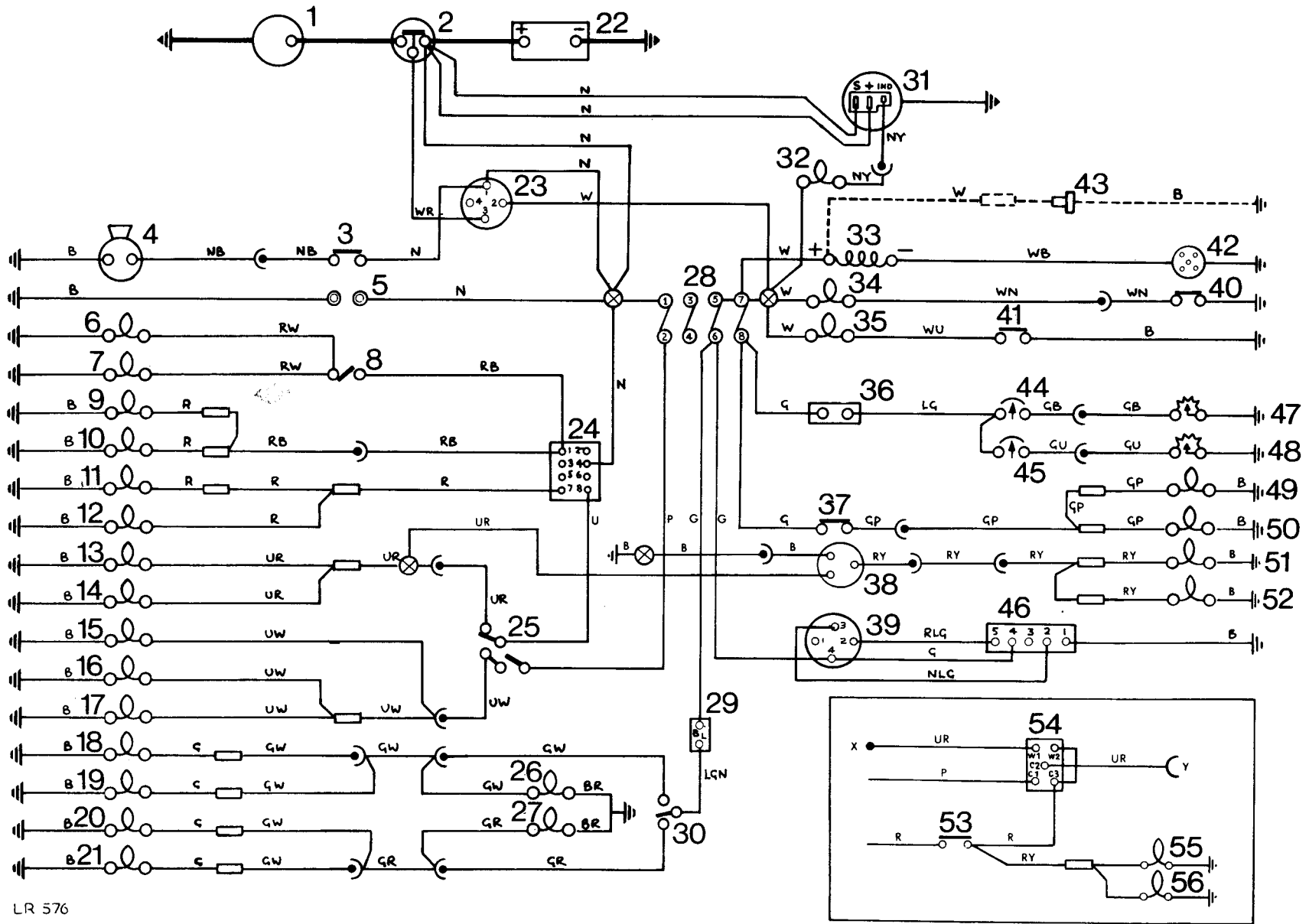

LR 576

## KEY TO CIRCUIT DIAGRAM 2¼ AND 2.6 LITRE PETROL MODELS, R.H. AND L.H. STEERING, NEGATIVE EARTH INCLUDING FOG LAMPS AND REAR FOG-GUARD LAMPS

1 Starter motor	20 Direction indicator lamp, front L.H.	38 Rear fog lamp switch and warning light
2 Solenoid, starter motor	21 Direction indicator lamp, rear L.H.	39 Switch, windscreen wiper
3 Switch for horns	22 Battery	40 Switch, oil pressure
4 Horns	23 Switch, ignition and starter	41 Switch, choke
5 Inspection sockets	24 Switch, lights	42 Distributor
6 Instrument panel illumination	25 Switch, headlamp flash and dip	43 Fuel pump (6-cylinder models only)
7 Instrument panel illumination	26 Warning light, indicator R.H.	44 Fuel gauge
8 Switch, panel lights	27 Warning light, indicator L.H.	45 Water temperature gauge
9 Tail lamp, L.H.	28 Fuses, 1 to 8, 35 amp	46 Screenwiper motor
10 Tail lamp, R.H.	29 Indicator unit, flasher	47 Fuel tank unit
11 Side lamp, L.H.	30 Switch, direction indicators	48 Water temperature transmitter
12 Side lamp, R.H.	31 Alternator, Lucas 16 ACR	49 Stop lamp, L.H.
13 Headlamp, L.H. dipped beam	32 Warning light, ignition	50 Stop lamp, R.H.
14 Headlamp, R.H. dipped beam	33 Ignition coil	51 Rear fog lamp, R.H.
15 Warning light, headlamp main beam	34 Warning light, oil pressure	52 Rear fog lamp, L.H.
16 Headlamp, L.H. main beam	35 Warning light, choke	53 Front fog lamp switch
17 Headlamp, R.H. main beam	36 Voltage stabilizer, fuel gauge and water temperature gauge	54 Fog lamp change over relay
18 Direction indicator lamp, rear R.H.	37 Switch, stop lamp	55 Front fog lamp, L.H.
19 Direction indicator lamp, front R.H.		56 Front fog lamp, R.H.

### Key to cable colours

B	Black	R	Red
G	Green	U	Blue
L	Light	W	White
N	Brown	Y	Yellow
P	Purple		

The last letter of a colour code denotes the tracer colour.

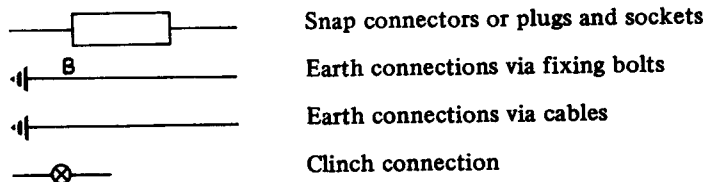

### CIRCUIT DIAGRAM 2¼ LITRE 4-CYLINDER DIESEL MODELS, R.H. AND L.H. STEERING, NEGATIVE EARTH INCLUDING FOG LAMPS AND REAR FOG-GUARD LAMPS

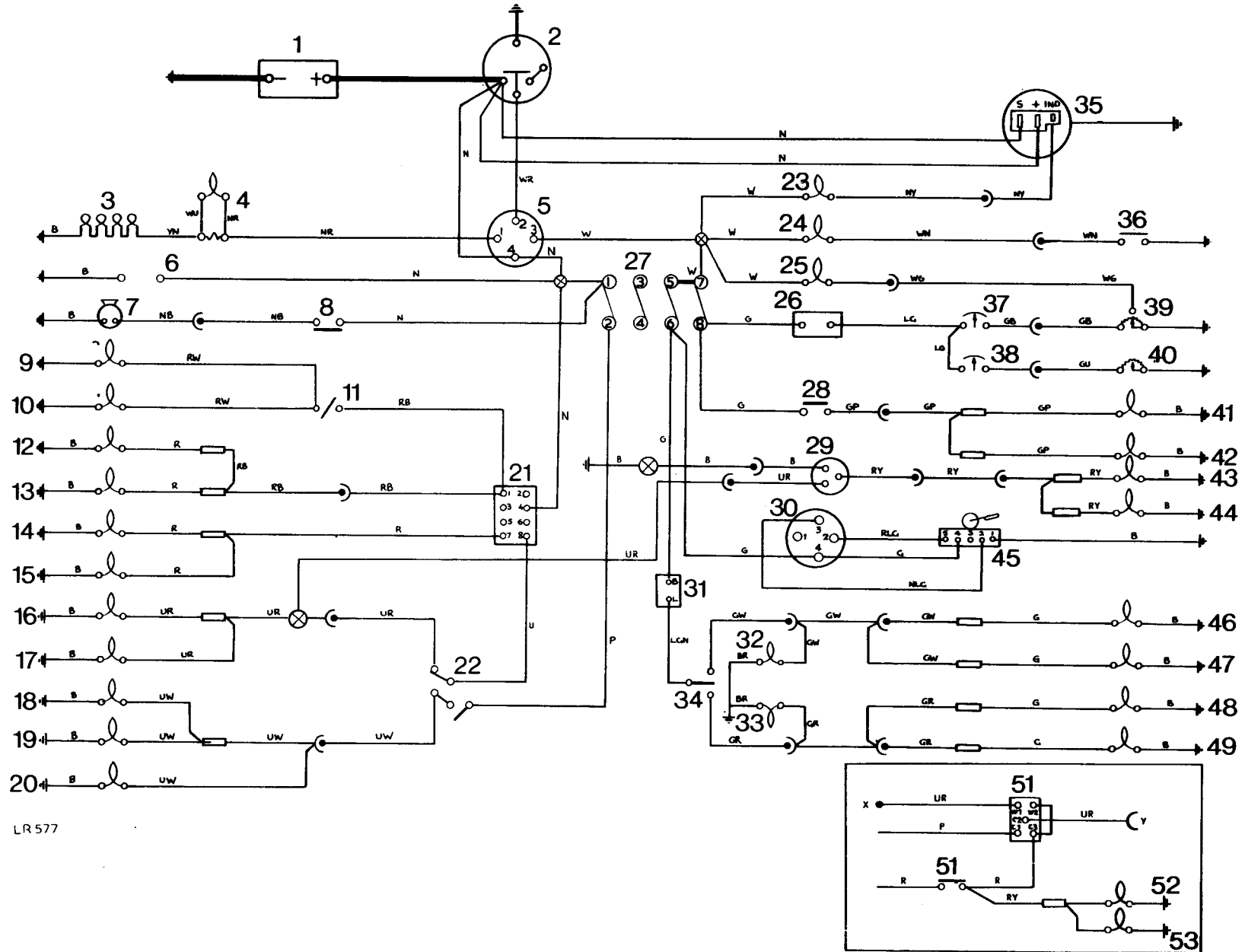

LR 577



## KEY TO CIRCUIT DIAGRAM 2¼ LITRE 4-CYLINDER DIESEL MODELS, R.H. AND L.H. STEERING, NEGATIVE EARTH INCLUDING FOG LAMPS AND REAR FOG-GUARD LAMPS

1	Battery	19	Headlamp, R.H. main beam	37	Fuel gauge
2	Starter motor solenoid	20	Headlamp main beam warning light	38	Water temperature gauge
3	Heater plugs	21	Lighting switch	39	Fuel tank unit
4	Cold start warning light and resistor	22	Switch, headlamp dip and flash	40	Water temperature transmitter
5	Start solenoid and switch	23	Charge warning light	41	Stop lamp, L.H.
6	Inspection sockets	24	Oil pressure warning light	42	Stop lamp, R.H.
7	Horn	25	Warning light, low fuel level	43	L.H. rear fog-guard lamp
8	Horn switch	26	Voltage stabilizer unit	44	R.H. rear fog-guard lamp
9	Instrument panel illumination	27	Fuses	45	Wiper motor
10	Instrument panel illumination	28	Stop lamp switch	46	R.H. front indicator
11	Panel light switch	29	Rear fog-guard lamp switch and indicator	47	R.H. rear indicator
12	Tail lamp, L.H.	30	Windscreen wiper switch	48	L.H. rear indicator
13	Tail lamp, R.H.	31	Flasher indicator unit	49	L.H. front indicator
14	Side lamp, R.H.	30	R.H. indicator warning light	50	Fog lamp change over relay
15	Side lamp, L.H.	33	L.H. indicator warning light	51	Front fog lamp switch
16	Headlamp, R.H. dipped beam	34	Indicator switch	52	L.H. front fog lamp } (if fitted)
17	Headlamp, L.H. dipped beam	35	Alternator	53	R.H. front fog lamp }
18	Headlamp, L.H. main beam	36	Oil pressure switch		

### Key to cable colours

B	Black	R	Red
G	Green	U	Blue
L	Light	W	White
N	Brown	Y	Yellow
P	Purple		

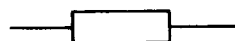
The last letter of a colour code denotes the tracer colour

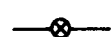
	Snap connection and/or plugs and sockets
	Earth connections via cables
	Earth connections via terminals or fixing bolts
	Clinch connection

**Alternator—Description**

The mechanical features of the alternator are a rotor supported by two ball bearings. No periodic lubrication is required. The field winding carried on the rotor is energized via a pair of brushes and slip-rings. Cooling air is drawn through the unit by a fan mounted at the drive end.

Electrically an alternating current produced in the three-phase, star-connected static stator windings is rectified by six diodes—three on the live side and three on the earth side—to supply direct current to the vehicle electrical circuits and battery.

The field winding circuit is energized by part of the stator output which is rectified by the three field winding supply diodes.

The integral control unit is electrically positioned in the field winding earth return path. Until a measure of control is required terminal 'F' is connected via the output transistor to earth. As the alternator output rises, the reference voltage felt at terminal 'S' rises. When control is required the solid state switching circuit governed by the voltage sensitive electronic circuit turns the output transistor off. The control unit thus finely adjusts the current flow through the field winding to balance the alternator output to suit the electrical requirements of the vehicle and the state of charge of the battery.

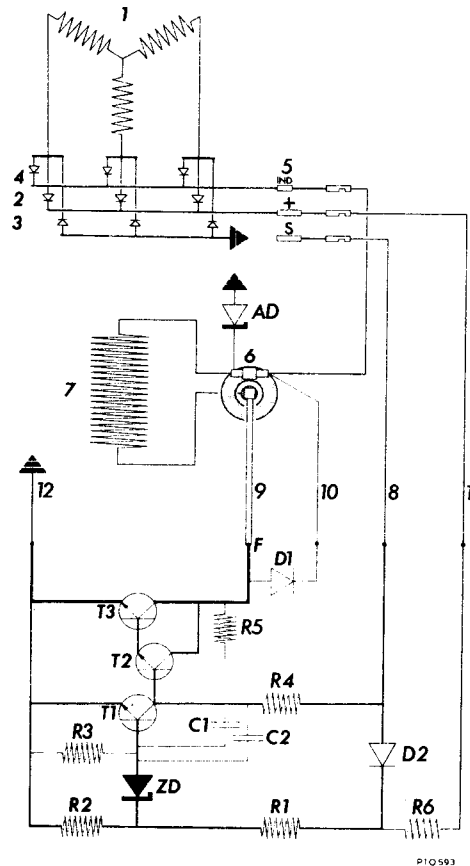

**ALTERNATOR WIRING DIAGRAM**

**Lucas 16ACR alternator with 14TR regulator**

**KEY**

- |           |                             |  |
|-----------|-----------------------------|--|
| 1         | Stator windings             |  |
| 2         | Live side output diodes     |  |
| 3         | Earth side output diodes    |  |
| 4         | Field winding supply diodes |  |
| 5         | European terminations       | IND Ignition warning light   |
|           |                             | + Main to battery  |
|           |                             | S Sense to battery   |
| 6         | Brushes and slip rings      |  |
| 7         | Field winding               |  |
| 8         | Battery sensed lead—white   |  |
| R4        | Resistor                    | Restricts TS base current supplied from 'battery sensed lead'.   |
| T2        | Intermediate transistor     | Controls T3 base current direct.   |
| 9         | Metal connector link        |  |
| T3        | Output transistor           | Controls field winding earth return circuit.   |
| R1 and R2 | Resistors                   | Potential divider – used in normal operation. Senses battery reference voltage.  |
| ZD        | Zener diode                 | Voltage sensitive component. Opposes passage of current until breakdown voltage – approximately 8 volts – is reached. Controls T1 base current direct.   |
| T1        | Input transistor            | Controls T2 base current by diverting current passing through R4 to earth when ZD is conducting.   |
| C1 and R5 | Capacitor and resistor      | Prevents transistor overheating by providing positive feedback circuit to ensure quick switching of transistors from 'fully on' to 'fully off'.  |
| R3        | Resistor                    | Path for small leakage current which may pass through ZD at high temperatures.   |
| 10        | Surge lead – yellow         |  |
| D1        | Surge quench diode          | Connected across field winding. Protects T3 from field winding high induced voltage surge and smooths field winding current.   |
| C2        | Condenser                   | Radio interference suppression.  |
| 11        | Machine sensed lead – red   |  |
| R6        | Resistor                    | Fail safe component. If main alternator to battery wire disconnects battery sensed lead voltage will fall. Alternator runaway voltage is clamped by high voltage on machine sensed lead. Modified potential divider R, R2 and addition R6. |
| D2        | Diode                       | Fail safe component. If battery sensed lead disconnects alternator shuts down as supply via R4 to transistors T2 and T3 stops. D2 blocks feed into this circuit from machine sensed lead via R6.   |
| AD        | Avalanche diode             | Protects output transistor from high transient voltage which may occur from faulty charging circuit connections.   |
| 12        | Earth lead – black          | Regulator earth.   |

## ALTERNATOR DATA

**CAUTION:** The alternator contains polarity sensitive components that may be irreparably damaged if subjected to incorrect polarity.

Do not connect or disconnect any part of the charging circuit—including the battery leads—while the engine is running. Run the alternator with all connections made or with the unit disconnected.

**NOTE:** Identify the unit on the specific vehicle to ensure that information obtained from this manual refers to the appropriate alternator.

Manufacturer	Lucas
Type	16 ACR Dual sensed—battery sensed with machine sensed safety control European terminations
Polarity	Negative earth only
Brush length—new	0.5 in (12.70 mm)
—renew if less than	0.2 in (5.00 mm) protrudes from brushbox when free
Brush spring pressure	9 to 13 oz (255 to 370 g) at face flush with brushbox
Rectifier pack—output rectification	6 diodes (3 live side and 3 earth side)
—field winding supply rectification	3 diodes
Stator windings	Three phase—star connected
Field winding rotor	
—poles	12
—maximum permissible speed	15,000 rev/min
—shaft thread	$\frac{9}{16}$ in — 18 U.N.F.
Field winding resistance at 20°C	3.3 ± 5% ohm
Regulator—type	14TR
Nominal output—condition	Hot
—alternator speed	6000 rev/min
—engine speed	3000 rev/min
—control voltage	14 volt
—amp	34 amp

## ALTERNATOR

### Functional check 86.10.01

This operation must be performed in two parts. The first to prove the alternator's capacity to produce current. The second to prove the performance of the integral regulator.

### Check capacity to produce current

**NOTE:** The stated output may be exceeded slightly when the alternator is cold. To avoid misleading results, the check should be performed with the unit as near

to its normal operating temperature as possible.

- 1 Check drive belt adjustment 86.10.05.
- 2 Disconnect the multi-socket connector.
- 3 Remove the cover, see 86.10.08, and provide a suitable probe and wire to enable the field winding earth brush to be earthed direct thus by-passing the regulator.
- 4 Provide a test circuit as shown.

**CAUTION:** The alternator contains polarity sensitive components that may be irreparably damaged if subjected to incorrect polarity. Observe polarity of alternator and battery terminals.

*continued*

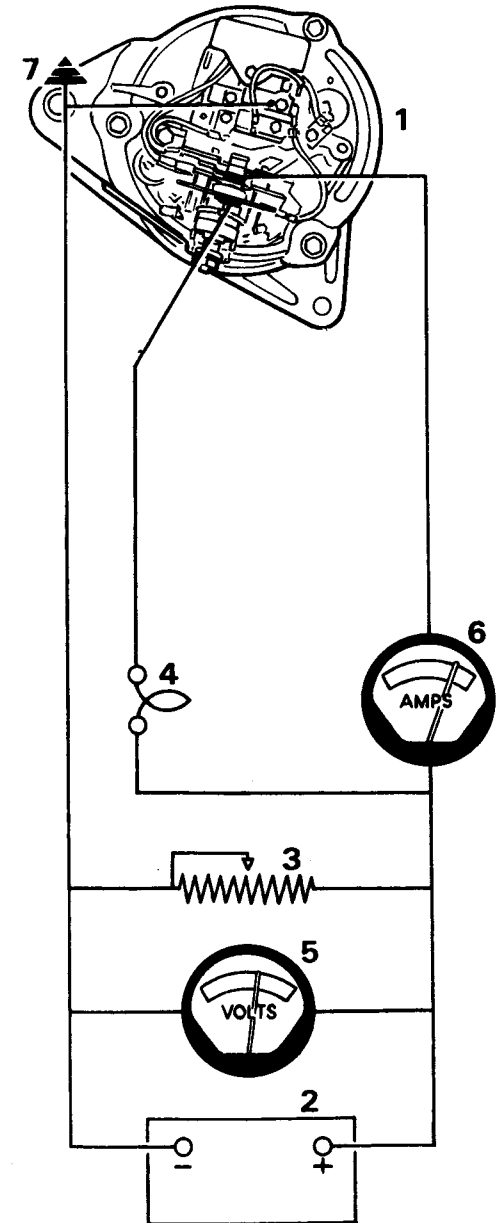

### Test circuit

- |   |                                     |                  |
|---|-------------------------------------|------------------|
| 1 | Alternator                          | 12 volt          |
| 2 | Battery                             | 12 volt          |
| 3 | Variable resistor                   | 70 amp           |
| 4 | Light                               | 12 volt—2.2 watt |
| 5 | Voltmeter                           | 0—20 volt        |
| 6 | Ammeter                             | 0—40 amp         |
| 7 | Earth connection to alternator body |                  |

LR 863

- 5 Do not connect the variable resistor across the battery for longer than is necessary to perform the check.
- 6 Run the engine.
- 7 Gradually increase the speed. At 1550 alternator rev/min (775 engine rev/min) the light should be extinguished.
- 8 Hold the speed at approximately 6000 alternator rev/min (3000 engine rev/min). Adjust the variable resistor so that the voltmeter reads 14 volts. The ammeter reading should now be approximately equal to the nominal output given in data.
- 9 If the ammeter reading is not correct the indication is that the alternator requires overhaul or replacement.

#### Diodes

- 10 Failure of one or more of the diodes will be indicated by the effect on alternator output, and in some instances by abnormally high alternator temperature and noise level. The fault symptom table shows how diode failure will influence alternator output test results. (Refer to 'Overhaul' 86.10.08, paragraph 19 for diode tests.)

*continued*

#### DIODE FAULT SYMPTOMS

Warning Light	Temperature	Noise	Output	Probable Fault (Associated Damage)
Illuminated at stand-still, extinguished at cut-in speed (1,500 rev/min) but at higher speeds becomes partially illuminated again and gets progressively brighter	High	Normal	Higher than normal at 6,000 rev/min. Approximately 40A	Live-side main output diode open circuit. (May damage rotor field winding and regulator, overheat, brushboxes, and fuse warning light bulb)
Not illuminated between zero at 1,500 rev/min	High	Excessive	Very low at 6,000 rev/min. Approximately 10A	Live-side main output diode short circuit. (May damage associated 'field' diode)
Illuminated at stand-still, dims appreciably at cut-in speed (1,500 rev/min) and gets progressively dimmer or may be extinguished at higher speeds	Normal	Excessive	Poor at low speed Slightly below normal at 6,000 rev/min. Approximately 32A	Earth-side main output diode open circuit
Illuminated at stand-still, dims appreciably at cut-in speed (1,500 rev/min) and gets progressively dimmer or may be extinguished at higher speeds	Normal	Normal	Lower than normal at 6,000 rev/min. Approximately 29A	'Field' diode open-circuit
Illuminated at stand-still, dims at cut-in speed (1,500 rev/min) and remains dim, but may be extinguished at very high speeds	Normal	Excessive	Very low at all speeds above cut-in (1,500 rev/min). Approximately 7A	Earth-side main output diode short-circuit, or stator winding short-circuit to earth
Illuminated at stand-still, dims at cut-in speed (1,500 rev/min) and remains dim, but may be extinguished at very high speeds	Normal	Excessive	Very low at 6,000 rev/min. Approximately 7A	'Field' diode short-circuit



### Check-Control unit

**NOTE:** The stated output may be exceeded slightly when the alternator is cold. To avoid misleading results, the check should be performed with the unit as near to its normal operating temperature as possible.

- 11 Check drive belt adjustment 86.10.05.
- 12 Disconnect multi-socket connector.
- 13 Provide a test circuit as shown.

**CAUTION:** The alternator contains polarity sensitive components that may be irreparably damaged if subjected to incorrect polarity. Observe polarity of alternator and battery terminals.

- 14 Run the engine.
- 15 Gradually increase the speed. At 1550 alternator rev/min (775 engine rev/min) the light should be extinguished.
- 16 Hold the speed at approximately 6000 alternator rev/min (3000 engine rev/min). The voltmeter reading should now be steady at 13.6 to 14.4 volts.
- 17 If the voltmeter reading is not steady at the above figure—and a satisfactory 'Check capacity to produce current' has been performed—the indication is that the control unit should be replaced.

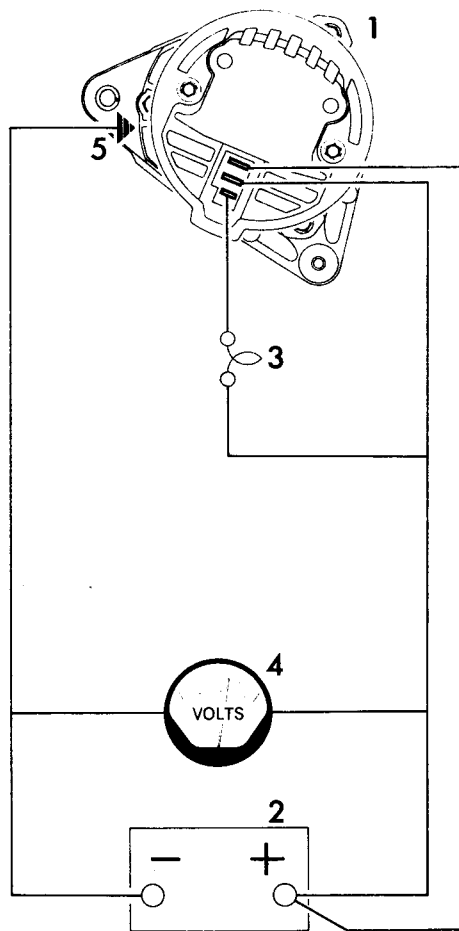

- |   |                                     |                  |
|---|-------------------------------------|------------------|
| 1 | Alternator                          |                  |
| 2 | Battery                             | 12 volt          |
| 3 | Light                               | 12 volt-2.2 watt |
| 4 | Voltmeter                           | 0-20 volt        |
| 5 | Earth connection to alternator body |                  |

## ALTERNATOR

### Remove and refit

86.10.02

#### Removing

- 1 Disconnect the battery.
- 2 Withdraw the electrical harness plug from the rear of the alternator.
- 3 Slacken the alternator fixings.

**NOTE:** The accompanying illustration shows an alternator installed on a 2½ litre 4-cylinder engine. On 2.6 litre 6-cylinder engines the alternator is mounted on the opposite side of the engine.

- 4 Pivot the alternator inwards and release the fan belt from the pulley.
- 5 Remove the fixings and withdraw the alternator.

#### Refitting

- 6 Fit the alternator, locating the fan belt over the pulley, but do not tighten the fixings at this stage.

**CAUTION:** When pivoting the alternator, leverage must only be applied to the alternator drive end bracket. Pressure applied to the stator or slip ring end bracket may result in serious damage.

- 7 **2½ litre 4-cylinder Petrol and Diesel engines**

Adjust the fan belt to give 6,5 mm to 9,5 mm (0.250 to 0.375 in.) free movement when checked midway between the fan and alternator pulleys.

- 8 **2.6 litre 6-cylinder Petrol engines**

Adjust the fan belt to give 8,0 mm to 11,0 mm (0.312 to 0.437 in.) free movement when checked midway between the fan and crankshaft pulleys.

- 9 Reconnect the electrical harness plug to the rear of the alternator.
- 10 Connect the battery.

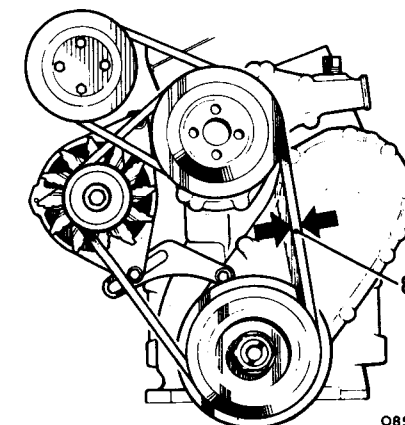
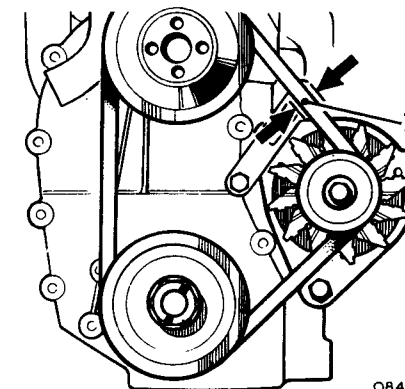
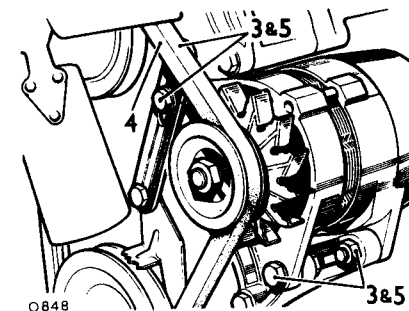

## ALTERNATOR—12 Volt (Lucas 16 ACR)

### Overhaul

86.10.08

- 1 Remove the alternator 86.10.02.
- 2 Carry out Bench test 86.10.14.
- 3 The following dismantling instructions are sufficient to enable the brushgear and slip-rings to be thoroughly inspected and serviced and the rotor and stator-windings and rectifier diodes to be electrically tested. If it is necessary to completely dismantle the alternator in order to renew a faulty part, refer to paragraphs 23–38.
- 4 Remove the moulded slip-ring end cover (two bolts).
- 5 Note the location of the three stator winding connections to the rectifier diode connecting pins, and then using a thermal shunt (long-nosed pliers are suitable) and a light weight soldering iron (25 watt) unsolder the connections to the rectifier. Use only resin cored solder for re-soldering.
- 6 Unclip the three leads from the rectifier plates.
- 7 Slacken the rectifier securing nut and detach the rectifier from the rest of the alternator.
- 8 Remove the hexagon-headed screw retaining the surge device lead to the brushbox moulding.
- 9 Remove the two hexagon-headed screws, securing the brushbox moulding to the end-face of the slip-ring end bracket. The brushgear-and-regulator sub-assembly can now be detached from the rest of the alternator.
- 10 To release the regulator remove the hexagon-headed screw retaining the yellow and orange leads to the brushbox moulding and the single bolt securing the regulator case.

**NOTE:** To ensure correct re-connection of the regulator, brushgear and rectifier see paragraph 36.

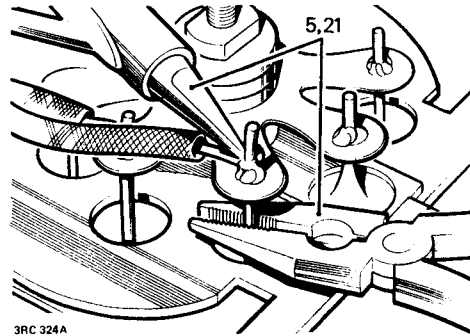

3RC 324A

### Brushgear

- 11 Check the brush spring pressure. With the brush-and-spring assemblies fitted in the brushbox moulding, apply a push-type spring gauge to the end-face of each brush in turn until the end-face of the brush is flush with the moulding. The spring pressure should then be 9–13 ozf (255–368 gmf).

### Rotor slip-rings

- 12 The slip-rings should be clean and smooth. If necessary, clean the slip-rings with a petrol moistened cloth. If the slip-rings are burnt and require refinishing, use very fine glass paper (not emery cloth, or similar abrasives) and afterwards wipe clean with a petrol-moistened cloth.

**NOTE:** It is essential that the re-finishing glass paper is sufficiently fine to produce a highly polished slip-ring surface, otherwise excessive brush wear will occur.

### Electrical testing of components

- 13 For clarity, illustrations of electrical testing show the components separated from the rest of the alternator.

### Rotor field winding

- 14 Check field winding continuity and resistance simultaneously, by connecting either a battery-operated ohmmeter (see 14 a) or a 12 V battery and moving-coil ammeter (see 14 b) between the slip-rings. The ohmmeter should indicate the appropriate resistance given in the General Data (86.10.14 sheet 4), or the ammeter should indicate a current approximate to the figure obtained by dividing the appropriate resistance of the rotor into the battery voltage.
- 15 Check for satisfactory field winding insulation by connecting a 110 V A.C. 15-watt test lamp between either of the slip-rings and the rotor body. The lamp should not light.

### Stator windings

- 16 Due to the very low resistance of the stator windings, a practical test to determine the presence of short-circuited turns cannot be carried out without the use of special instruments. However, in practice inter-winding short-circuiting is usually indicated by obvious signs of burning of the insulating varnish covering the windings. If this is the case, renew the stator assembly without the need for further testing.
- 17 Check continuity of stator windings, by first connecting any two of the three stator winding connecting cables in series with a 12 V battery-operated test lamp, of not less than 36 watts. The test lamp should light. If not, renew the stator assembly. Providing the first part of the test is satisfactory, transfer one of the test lamp leads to the other (third) cable. Again the test lamp should light. If so, proceed to insulation test.
- 18 Check insulation of stator windings, by connecting a 110 V A.C. 15-watt test lamp between the stator laminations and any one of the three connecting cables. The lamp should not light.

*continued*

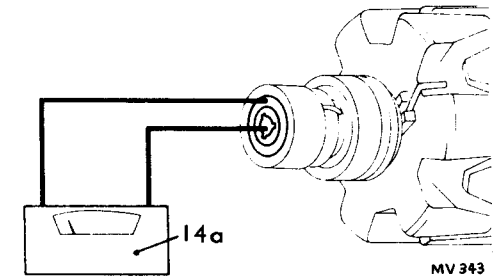

MV 343

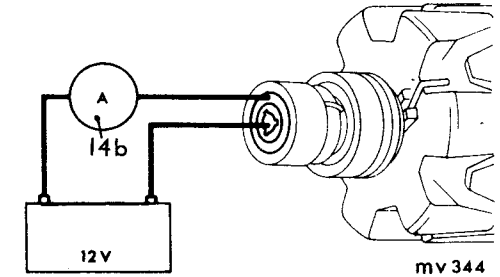

mv 344

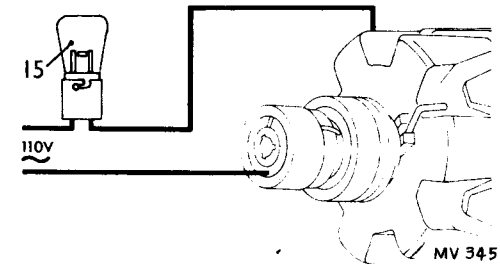

MV 345

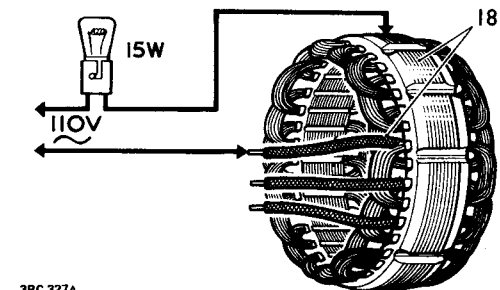

3RC 327A

### Rectifier diodes

- 19 Test each of the nine diodes separately, as follows.
- 20 Connect a 12 V battery and a 1.5 watt bulb in series with one of the diodes, one test lead being applied to the diode connecting pin and the other to the particular heat sink plate in which the diode undergoing test is soldered. Note whether lamp lights, then reverse the test lead connections. The lamp should light during one half of the test only. If any one diode test is unsatisfactory, renew the rectifier assembly.
- 21 During reassembly of the alternator, use only 'M' grade 45-55 resin-cored solder to attach the stator cables to the diode connecting pins. Carry out the operation as quickly as possible, using a thermal shunt to avoid damaging the diode(s) (Long-nosed pliers are suitable as a thermal shunt).

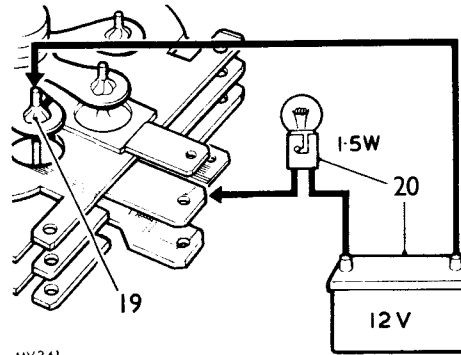

MV341

- 26 Separate the rotor assembly from the drive-end bracket. First remove the driving pulley fan and shaft key, then press the rotor shaft from the bearing in the bracket. Alternatively, use the open jaws of a vice to support the bracket and carefully drive the rotor shaft from the bearing by a series of light blows applied to the end of the shaft with a hide, plastic, or wooden mallet. (Open the jaws of the vice sufficient only to clear the rotor poles, position the bracket off-set to the centre of the top of the vice to avoid

the slip-ring moulding fouling the bottom of the vice, and temporarily fit the shaft nut flush with the end of the shaft to avoid damage to the shaft threads by the mallet).

- 27 If it is necessary to renew either the slip-ring moulding assembly or slip-ring end bearing the slip-ring moulding assembly can be withdrawn from the key-way in the rotor shaft after the field winding connections have been unsoldered. Use a light weight soldering iron (e.g. 25 watt). Use only resin-cored solder for resoldering.

*continued*

### Regulator

- 22 Individual testing of the regulator can only be carried out with special test equipment and unless this is available the regulator must be proved by substitution.

### Alternator—complete dismantling

- 23 Remove the three through bolts.
- 24 Grip both ends of the alternator in the hands, pull apart the end brackets from the stator laminations and separate the alternator into three major parts.
  - (1) Slip-ring end bracket.
  - (2) Stator laminations-and-windings.
  - (3) Sub-assembly comprising:
    - Fan and pulley;
    - Drive-end bracket and bearing;
    - Rotor complete with slip-ring end bearing.
- 25 If difficulty is experienced in separating the above parts, suspend the alternator gripped by the pulley in one hand and apply a series of light blows with a hide, plastic, or wooden mallet in turn to the shoulders of the through bolt housings of the slip-ring end bracket.

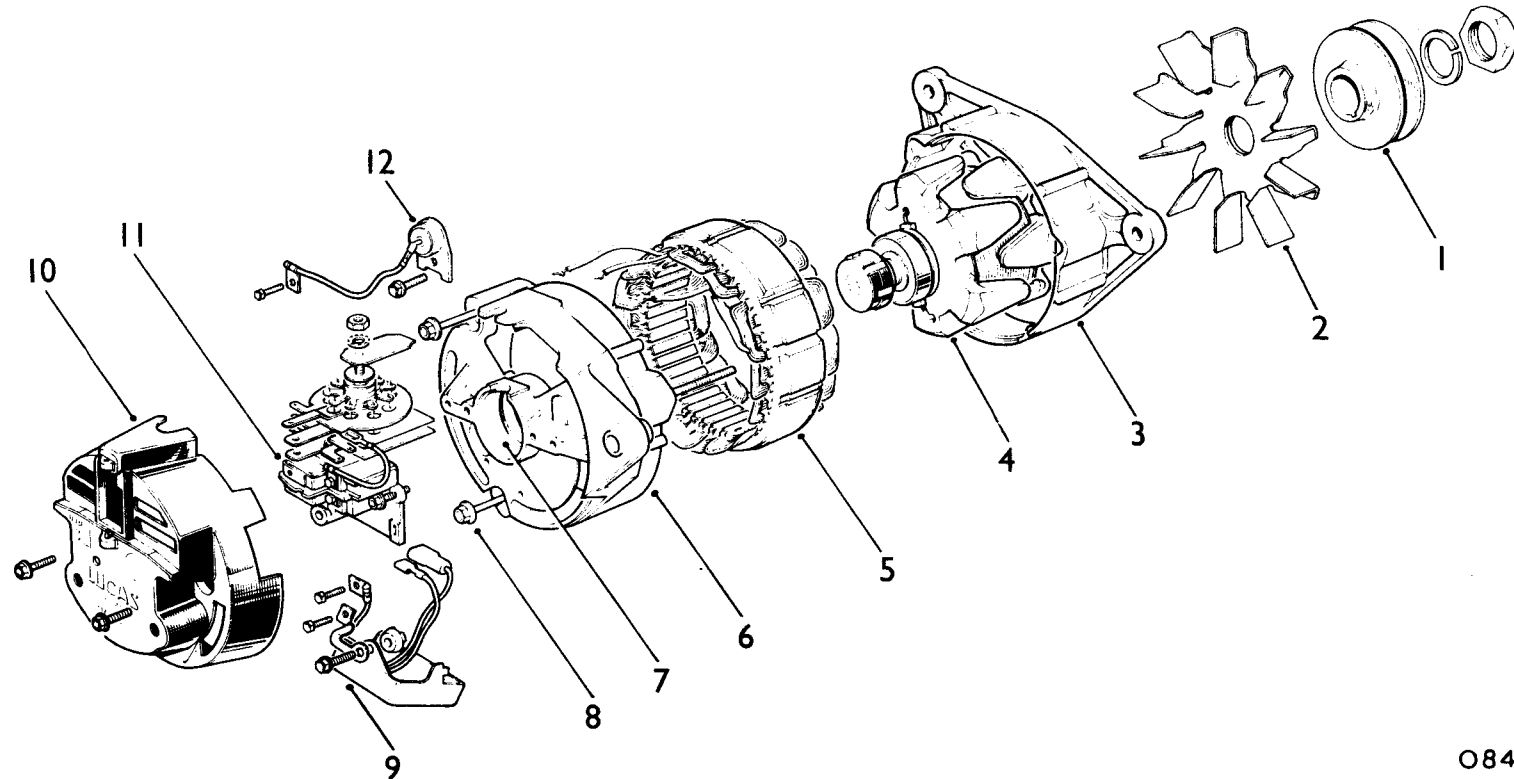

16 ACR Alternator

- |                       |                         |                                       |
|-----------------------|-------------------------|---------------------------------------|
| 1 Pulley              | 5 Stator                | 9 Regulator                           |
| 2 Fan                 | 6 Slip ring end bracket | 10 Moulded end cover                  |
| 3 Drive end bracket   | 7 'O' ring              | 11 Rectifier                          |
| 4 Rotor and slip-ring | 8 Through bolts         | 12 Surge protection (Avalanche) diode |

O847

**Bearings**

28 Check whether the bearings need renewing. Determine this by first inspecting the rotor and stator poles for signs of rubbing. If so, excessively worn bearings are indicated and both should be renewed. If there is no visible evidence of worn bearings, check whether the bearings are worn to the extent of allowing perceptible side movement of the rotor shaft and if so the bearing(s) should be renewed.

**Renewing the bearings**

29 After removing the slip-ring moulding from the rotor shaft (refer to paragraph 27), the slip-ring end bearing can be removed from the rotor shaft and then either renewed or if otherwise satisfactory re-packed with grease lubricant (refer to paragraph 32). Position the two halves of the support plate of a hand-operated power press beneath the shoulder of the nylon distance-piece and press the rotor shaft from the bearing. Alternatively, use a suitably-sized claw-type bearing extractor tool (position claws behind the shoulder of the nylon distance-piece) and pull the bearing from the shaft.

**NOTE:** When refitting the bearing, ensure the shielded side of the bearing faces the slip-ring moulding.

30 After removing the bearing retaining circlip and plate, the drive-end bearing can either be pressed or carefully tapped from the bracket with a suitably-sized mandrel inserted in the outer-face aperture of the bearing housing.

**NOTE:** When refitting the bearing, ensure correct sequence of assembly of sundry parts associated with the bearing.

**Lubrication of bearings**

31 During major overhaul of the alternator, providing the bearings have been checked and found not to be excessively worn, bearings can be serviced by re-packing with Shell Alvania 'RA' grease lubricant, or equivalent.

32 To re-pack the slip-ring end bearing with grease it will be necessary to gain access to the unshielded (open) side of the bearing, by removing first the slip-ring moulding and then the bearing from the rotor.

**Reassembly**

33 Reassembly of the alternator is simply a reversal of the dismantling procedure. It should be noted that the sub-assembly comprising rotor and drive-end bracket, stator assembly and slip-ring end bracket (secured by three through bolts) can be incorrectly assembled in two or three alternative ways which causes mis-alignment of the alternator fixing lugs of each end bracket.

34 Assuming the rotor assembly to be already fitted in the drive-end bracket, mis-alignment of the end brackets previously referred to can be avoided by first fitting the stator assembly correctly in the drive-end bracket. (In preference to first fitting the stator assembly in the slip-ring end bracket).

35 Fit the stator assembly in the drive-end bracket so that the stator connecting leads are positioned between and in line with the alternator fixing lugs, then assemble the slip-ring end bracket to the stator lamination and finally secure into a sub-assembly by fitting the through bolts.

36 Avoid over-tightening the through bolts, the maximum tightening torque is 55 lbf in (63 cmf. kg).

37 Tighten the shaft nut to a torque figure of 25 to 30 lbf. ft. (3,5 to 4,2 kgf. m.).

38 Reconnect the leads between the regulator, brushbox and rectifier as illustrated.

39 Refit the alternator 86.10.02.

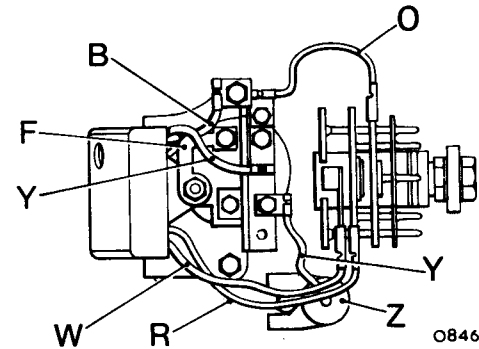

12 volt 16 ACR alternator connections

- B black lead
- F metal link
- O orange lead
- R red lead
- W white lead
- Y yellow lead
- Z surge protection

**BATTERY**

Remove and refit

86.15.01

**Removing**

- 1 Disconnect the battery leads.
- 2 Remove the air cleaner 19.10.08 (6 cyl. petrol models only).
- 3 Remove the wing nuts securing the battery clamp frame.
- 4 Remove the clamp frame.
- 5 Remove the battery.

**Refitting**

- 6 Reverse instructions 1 to 5.

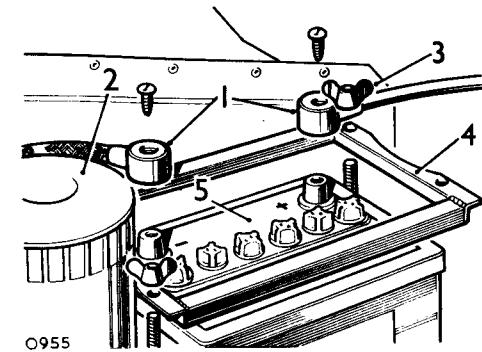
**IMPORTANT NOTE**

If a new battery is fitted to the vehicle, it should be the same type as fitted to the vehicle when new; see Section 04. Alternative batteries may vary in size and terminal positions and this could be a possible fire hazard if the terminals or leads come into contact with the battery clamp assembly. When fitting a new battery ensure that the terminals and leads are clear of the battery clamp assembly.

## HORN

Remove and refit

86.30.09

### Removing

- 1 Disconnect the battery.
- 2 Remove the radiator grille.
- 3 Disconnect the electrical leads from the horn.
- 4 Remove the bolts securing the horn.
- 5 Withdraw the horn.

### Refitting

- 6 Reverse instructions 1 to 4.

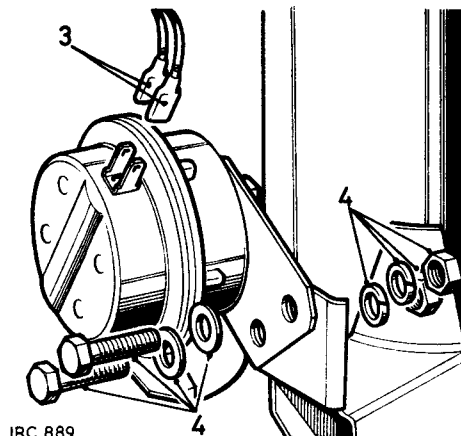

## HEATER PLUGS

Remove, clean and refit

86.35.08

### Removing

- 1 Disconnect the battery.
- 2 Remove the knurled terminal nuts from the heater plugs.
- 3 Detach the heater plug leads and insulators.
- 4 Remove the heater plugs.

### Cleaning

- 5 Remove carbon from base of heater plugs to avoid the possibility of short circuiting of the element. Do not sandblast.
- 6 Examine the element for signs of fracture and deterioration and the seating for scores. Plugs with fractures or doubtful elements must be renewed. Where scoring of the seating may impair the sealing, the plug should be renewed.
- 7 Test the plug internal circuit for continuity by connecting it in circuit with a 12 volt side lamp bulb and a 12 volt supply. If the bulb does not light an open circuit is indicated and the heater plug must be renewed.

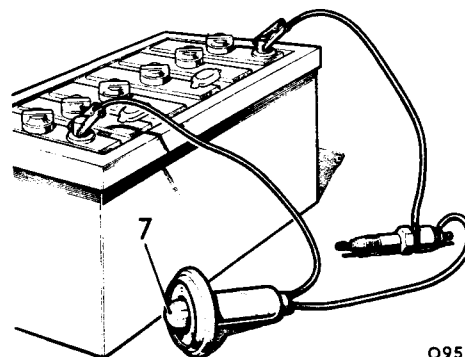
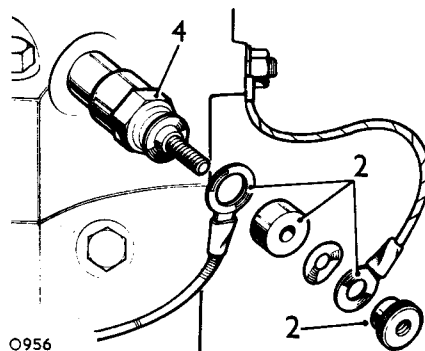

### Refitting

- 8 Ensure that the terminals are clean and that the thread at the base of the plug is free from carbon.
- 9 Fit the heater plugs to the engine. Torque 3,4 kgf. m. (25 lbf. ft.).
- 10 Fit the heater plug leads and insulators.
- 11 Connect the battery.

### Fault location in heater plug circuit, plugs in situ

The heater plugs do not require any maintenance. However, if at any time when the heater plugs are in use, the warning light glows very brightly, a short circuit in the system is indicated. No light will indicate an open circuit.

Great care must be taken not to twist the centre terminal when removing heater plug leads.

- 12 Examine the fuse in the fuse box and fit a new replacement if necessary. Refer to the applicable circuit diagram for fuse location.
- 13 Failure of the warning light bulb will not affect the heater plug circuit, but the bulb should be replaced when conveniently possible.
- 14 Connect one lead of a 12 volt test lamp to the earth lead terminal on No. 1 heater plug and the other lead to the positive terminal of the battery.
- 15 If the test lamp does not light, a faulty earth lead is indicated.
- 16 Move the test lamp lead from the heater plug earth lead terminal to the interconnecting lead terminal. If the test lamp remains unlighted, a broken heater plug filament is indicated.
- 17 Check the remaining plugs in the same manner until the fault is located.
- 18 If the plugs are proved serviceable, check each terminal of the resistance in the same manner. If the resistance and the output lead are proved to be serviceable, check the input lead and starter switch.

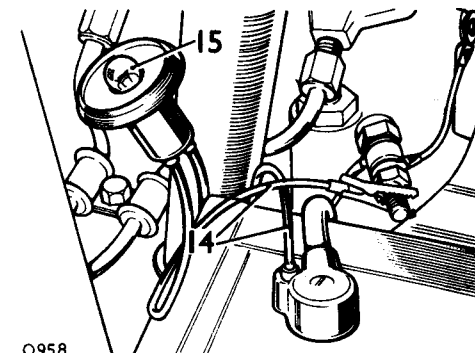

## CONTACT BREAKER POINTS — 2¼ litre Petrol engines

Remove and refit 86.35.13

### Removing

- 1 Remove the distributor cap and the rotor arm.
- 2 Ease the spring of the moving contact point clear of its nylon insulating block.
- 3 Detach the connector strip and the low tension and condenser leads from the spring.
- 4 Remove the screw and washers securing the fixed contact to the distributor base plate.
- 5 Remove the contact breaker points.

### Refitting

- 6 Reverse instructions 2 to 5. Do not tighten the contact breaker securing screw at this stage.
- 7 Rotate the engine until the lobe of the rotor opens the points fully.
- 8 Adjust the position of the fixed cam to obtain a contact breaker gap of 0.014 to 0.016 in. (0,36 to 0,40 mm).
- 9 Tighten the securing screw.
- 10 Fit the rotor arm and distributor cap.

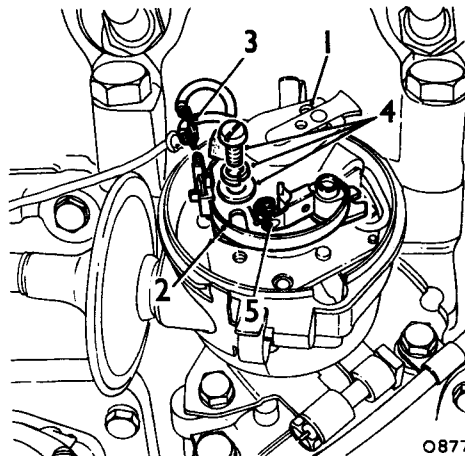

## CONTACT BREAKER POINTS — 2.6 litre Petrol engines

Remove and refit 86.35.13

### Removing

- 1 Remove the distributor cap and rotor.
- 2 Remove the nut, insulation bush, low tension and capacitor leads.
- 3 Remove the lock screw, spring washer and plain washer.
- 4 Lift out the contact assembly and insulation bushes.

### Refitting

- 5 Wipe the preservative from the new contact faces.
- 6 Engage the contact spring on to one of the insulation bushes.
- 7 Locate the contact assembly in position and retain with the lock screw, spring washer and plain washer.
- 8 Locate the capacitor lead, low tension lead and upper insulation bush in position and secure the nut.
- 9 Adjust the contact gap, see 96.35.14.

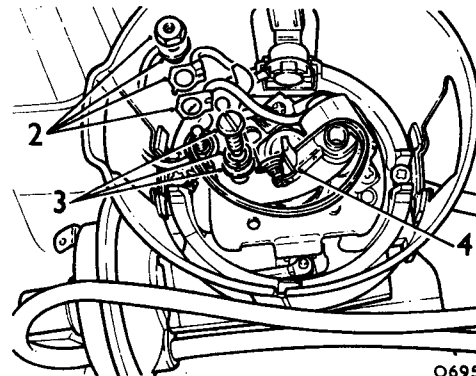

## DISTRIBUTOR — 2¼ litre and 2.6 litre Petrol engines

Contact gap—adjust 86.35.14

- 1 Remove the distributor cap and the rotor arm.
- 2 Rotate the crankshaft to position the contact heel on a cam peak.
- 3 If the contact gap is correct a 0,35 to 0,40 mm (0.014 to 0.016 in.) feeler gauge will just slide between the contacts.
- 4 When the contact gap is correct operations 6 to 8 may be ignored.
- 5 If correction is required slacken the lock screw.
- 6 Move the fixed contact about the pivot to adjust the gap. This may be facilitated by inserting a screwdriver between the slot as shown and twisting to position the fixed contact.
- 7 Tighten the lock screw.
- 8 Check that the correct gap has been maintained.

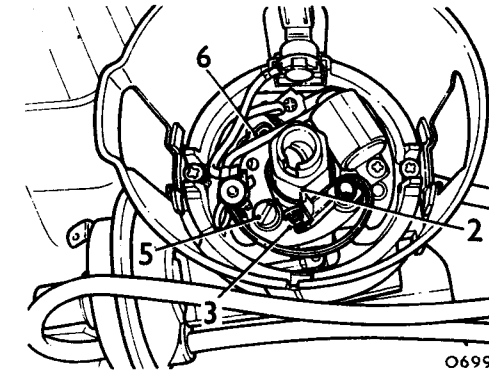
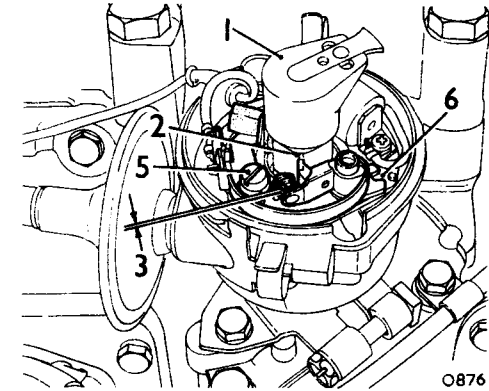

## DISTRIBUTOR

Ignition Timing—adjust 86.35.15

### Static

- 1 Remove the distributor cap.
- 2 Check, and if necessary, adjust the contact breaker gap to 0,35 to 0,40 mm (0.014 to 0.016 in.) see 86.35.14.

**NOTE:** Land Rover petrol engines are produced with compression ratios of:

2½ litre	8:1 and 7:1
2.6 litre	7.8:1 and 7:1

The compression ratio is indicated by the commencing three digits of the engine number as follows:

Compression ratio	Engine numbers commence	
8:1	} 2½ litre	901
7:1		904
7.8:1	} 2.6 litre	941
7:1		944

Ignition settings are:

### 2½ litre engine

- 8:1 compression ratio T.D.C. with 90 octane fuel
- 7:1 compression ratio 3° B.T.D.C. when using 83 octane fuel

### 2.6 litre engine

- 7.8:1 compression ratio 2° A.T.D.C. when using 90 octane fuel
- 7:1 compression ratio 2° B.T.D.C. when using 83 octane fuel

- 3 The timing marks are carried on the crankshaft pulley and the timing pointer is mounted on the timing gear cover.

**NOTE:** Two types of timing marks are in use, either a multiple pointer with a single mark on the pulley, or single pointer with a scale of marks on the pulley.

The multiple pointer represents 6° B.T.D.C., 3° B.T.D.C., T.D.C. and 6° A.T.D.C. respectively.

The scale on the pulley represents 6° B.T.D.C., 3° B.T.D.C., T.D.C., 3° A.T.D.C. and 6° A.T.D.C.

- 4 Rotate the engine in direction of rotation until the appropriate timing mark is aligned with the pointer and the distributor rotor is at No. 1 cylinder firing position.

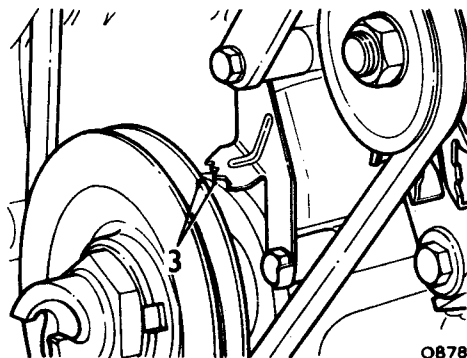

O878

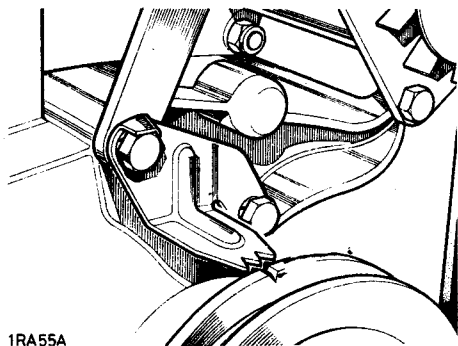

1RA55A

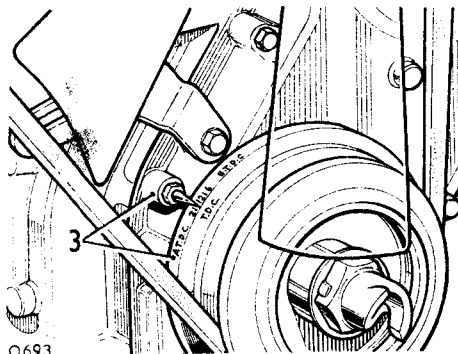

O693

- 5 Slacken the pinch bolt in base of distributor body and rotate the distributor in opposite direction to arrow on rotor arm until the contact breaker points are just opening with the cam follower on the leading side of the cam.

Re-tighten the pinch bolt.

- 6 Connect a 12 volt test lamp from the distributor l.t. terminal to earth.
- 7 Switch 'on' the ignition.
- 8 Rotate the engine two revolutions in the direction of rotation. The test lamp should light up as the timing pointer aligns with the appropriate mark on the crankshaft pulley.
- 9 Adjust as required by slackening the pinch bolt and turning the distributor bodily.

**NOTE:** If the distributor is the type with an external adjuster, this can be used for fine adjustment.

- 10 When satisfactory, secure the pinch bolt, remove the test lamp and leads and, refit the distributor cap.

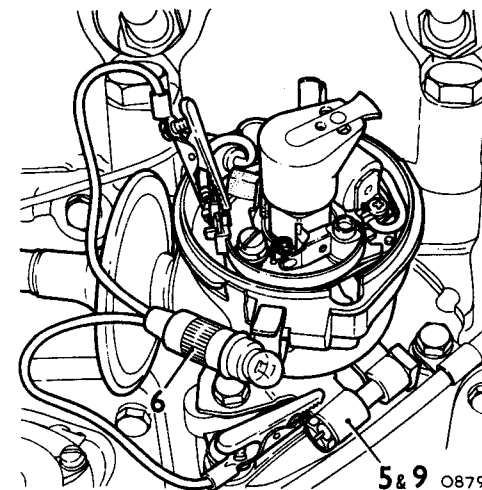

5&9 O879

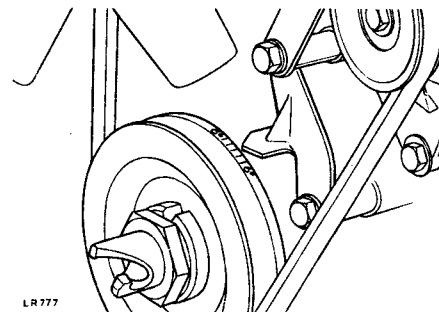

LR777

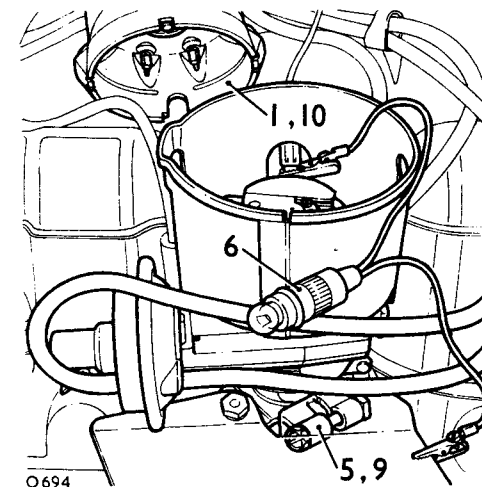

O694

## DISTRIBUTOR—2¼ litre Petrol engines

Remove and refit 86.35.20

### Removing

- 1 Prop open the bonnet.
- 2 Remove the air cleaner, see 19.10.01.
- 3 Disconnect the vacuum pipe at the distributor.
- 4 Disconnect the leads at the sparking plugs.
- 5 Disconnect the h.t. and l.t. leads at the coil.
- 6 Remove the one bolt, spring washer and plain washer securing the clamp bracket to the pedestal.
- 7 Withdraw the distributor.

### Refitting

- 8 Rotate the crankshaft until No. 1 piston is at TDC and the offset slot in the distributor drive gear is in the position shown.
- 9 Align the drive dog on the distributor with the offset slot in the drive gear and fit the distributor.
- 10 Remove the distributor cap; the distributor rotor arm should be in the No. 1 cylinder firing position and the distributor vacuum unit toward the rear of the engine.
- 11 Check, and if necessary, adjust the ignition timing, see 86.35.15.
- 12 Refit the air cleaner.

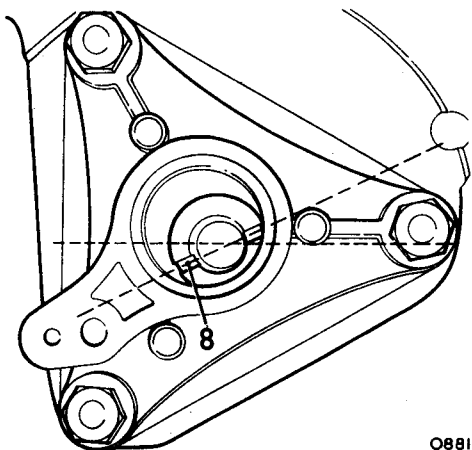
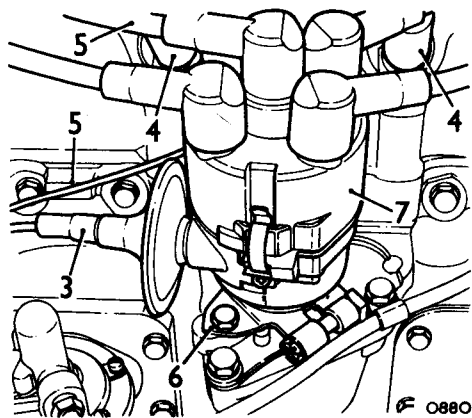

## DISTRIBUTOR—2.6 litre Petrol engines

Remove and refit 86.35.20

### Removing

- 1 Disconnect the vacuum pipe(s) at the distributor.
- 2 Disconnect the leads at the sparking plugs.
- 3 Disconnect the h.t. and l.t. leads at the distributor.
- 4 Remove the fixings and withdraw the distributor complete with heat shield from the drive housing.
- 5 If required, lift out the short drive shaft from the drive housing.

### Refitting

- 6 If a new distributor is being fitted, check, and if necessary, adjust the contact breaker complete gap to 0,35 to 0,40 mm (0.014 to 0.016 in.).
- 7 If the distributor is the type with an external adjuster on the side of the body, set the knurled adjuster so that the fourth line on the calibrated slide is against the distributor body casing.
- 8 If removed, refit the short drive shaft to engage the offset drive.
- 9 Remove the side and top rocker covers.
- 10 Rotate the engine until the offset slot in the short drive shaft is positioned as illustrated with both valves closed on No. 1 (front) cylinder (that is, with No. 1 cylinder on firing stroke).
- 11 Align the drive dog on the distributor with the offset slot in the drive shaft and fit the distributor.
- 12 Remove the distributor cap; the distributor rotor arm should be in the No. 1 cylinder firing position and the distributor vacuum unit toward the front of the engine.
- 13 Check, and if necessary, adjust the ignition timing, see 86.35.15.
- 14 Refit the side and top rocker covers.

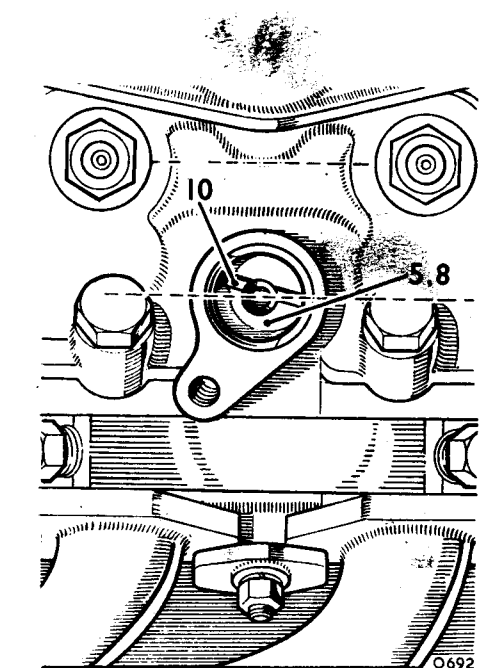
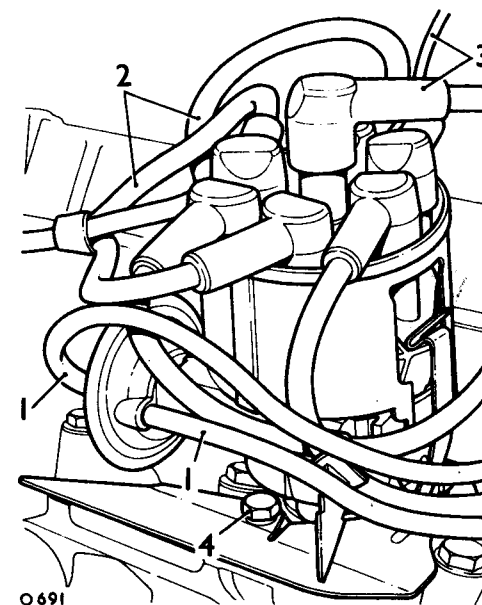



**DISTRIBUTOR—2¼ litre Petrol engines**

Overhaul 86.35.26

**Dismantling**

- 1 Remove the distributor from the vehicle, see 86.35.20.
- 2 Remove the distributor cap.
- 3 Withdraw the rotor arm.
- 4 Remove the screw, spring washer and plain washer and lift out the contact assembly.
- 5 Push the contact spring out of the terminal block and withdraw the terminal plate.
- 6 Withdraw the felt pad from the top of the camshaft.
- 7 Remove the capacitor screw. Manoeuvre the low tension lead grommet inwards towards the centre of the unit. Remove the capacitor and low tension lead connected together.
- 8 Remove two screws and anti-vibration washers. Withdraw the vacuum advance unit.
- 9 Remove the screw to release the expandable limb. Lift out the moving plate earth lead.
- 10 Using a small screwdriver push the expanded limb of the base plate inwards to release it from the body chamfered undercut. Lift out the plate assembly.
- 11 Tap out the drive gear pin. Remove the drive gear and thrust washer. Ensure that the shaft is burr-free and withdraw it.
- 12 Remove the distance collar.
- 13 Remove the control springs, exercising care not to distort the springs.

**Reassembling**

- 14 Lubricate the action plate, weight and cam assembly working surfaces with Rocol 'Moly pad'.
- 15 Fit the control springs, exercising care not to distort the springs.
- 16 Fit the distance collar.
- 17 Lubricate the shaft with Rocol 'Moly pad' and insert it into the body. Fit the thrust washer and drive gear. Secure with the drive gear pin.

- 18 Temporarily fit one screw and anti-vibration washer adjacent to one clip as shown. This is to facilitate operation 19 below.
- 19 Lubricate the moving plate pin with Rocol 'Moly pad'. Position the plate assembly so that the two downward facing prongs straddle the screw fitted at operation 18 above. Push the plate assembly downwards until it 'clicks' into the body chamfered undercut.
- 20 Position the moving plate earth lead tag. Fit the screw to expand the expandable limb.
- 21 Temporarily remove the screw and anti-vibration washer fitted at operation 18 above.
- 22 Lubricate the vacuum advance unit link hole with Rocol 'Moly pad'. Insert the vacuum advance unit so that the moving plate pin engages correctly in the link hole. Secure first with one screw and anti-vibration washer in the round hole. Secure secondly with one screw and anti-vibration washer in the elongated hole.
- 23 Thread the low tension lead outwards through the body hole. Manoeuvre the lead grommet into position. Position the capacitor and the moving plate earth lead tag. Secure with the capacitor screw.
- 24 Slide the moving contact from the post. Lightly grease the post with Shell Retinax A or equivalent. Fit the moving contact to the post.
- 25 Wipe the preservative from the new contact faces.
- 26 Clip the terminal plate to the contact spring.
- 27 Engage to contact spring in the terminal block.
- 28 Position the contact assembly and secure with the screw, spring washer and plain washer.
- 29 Lightly grease the cam with Shell Retinax A or equivalent.
- 30 Apply a few drops of engine oil to lubricate the cam spindle bearing.
- 31 Position the felt pad.
- 32 Fit the rotor arm.
- 33 Fit the distributor cap.
- 34 Refit the distributor to the vehicle.

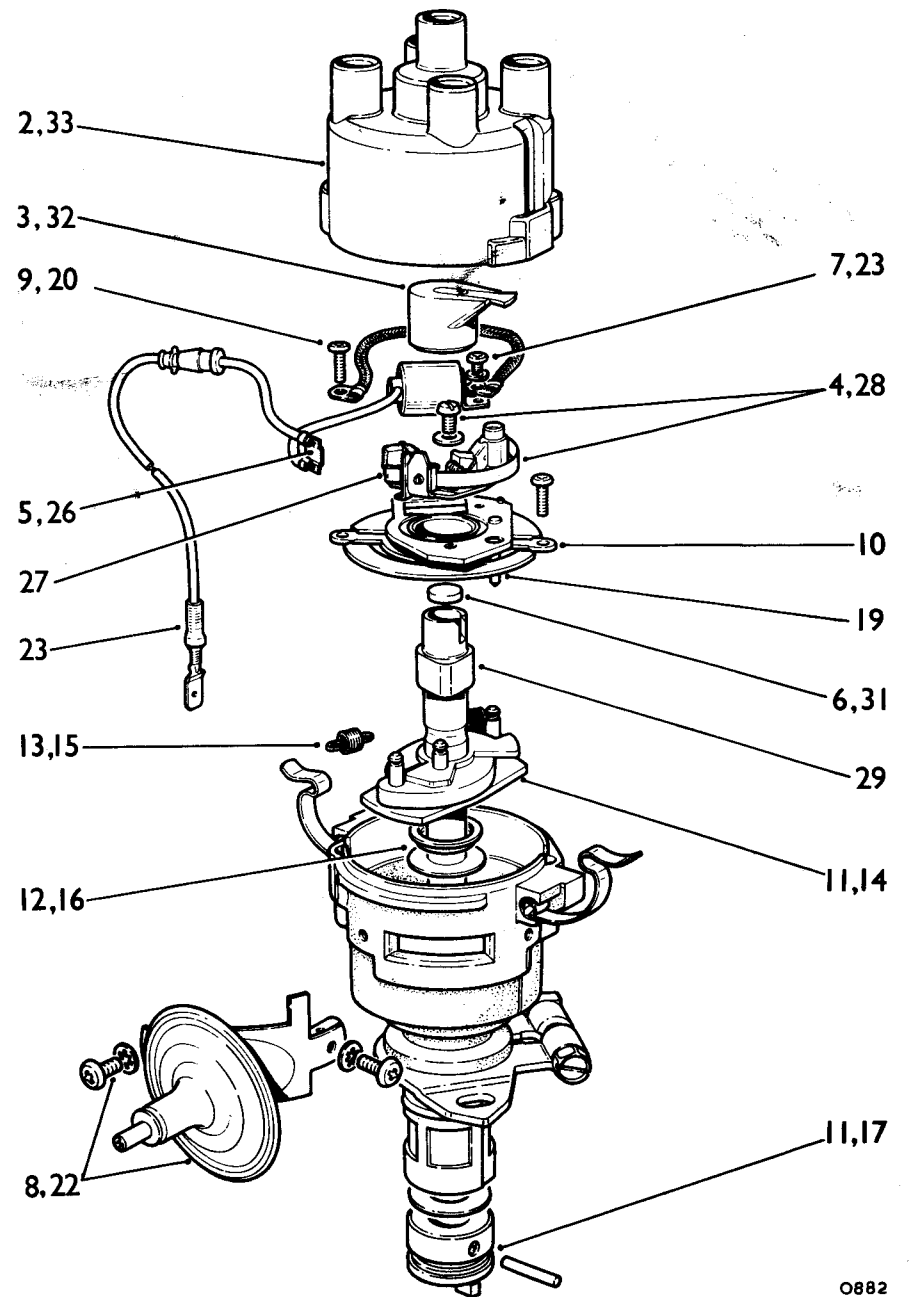

## DISTRIBUTOR—2.6 litre Petrol engines

### Overhaul

86.35.26

**NOTE:** There are three variants of distributor in use in order to comply with particular engine specifications. The variations can include a screen cover around the cap and/or an external adjuster on the side of the body, or neither. The following instructions apply to all variants.

#### Dismantling

- 1 Remove the distributor from the vehicle, see 86.35.20.
- 2 Remove the distributor cap.
- 3 Withdraw the rotor arm.
- 4 If the distributor is fitted with a screen cover, remove the two screws and washers and lift off the cover.
- 5 Disconnect the low tension and capacitor leads from the contact assembly.
- 6 Withdraw the low tension lead complete with terminal block.
- 7 Remove the contact assembly complete.
- 8 Remove the capacitor.
- 9 If the distributor is the type with only one connector tube on the vacuum unit, disconnect the spring between the vacuum unit and the base plate then remove the base plate assembly.
- 10 If the distributor is the type with two connector tubes on the vacuum unit, push the base plate downward and lift the vacuum unit arm from the pivot pin on the base plate and withdraw the base plate assembly.
- 11 Rotate the contact breaker moving plate clockwise to its full extent and withdraw it from the base plate.

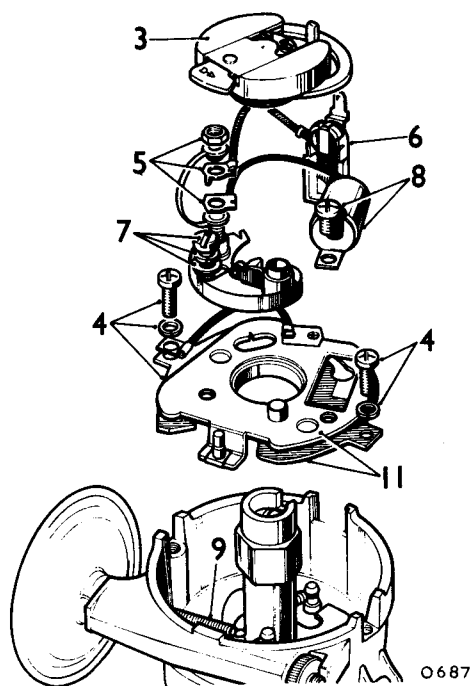

O687

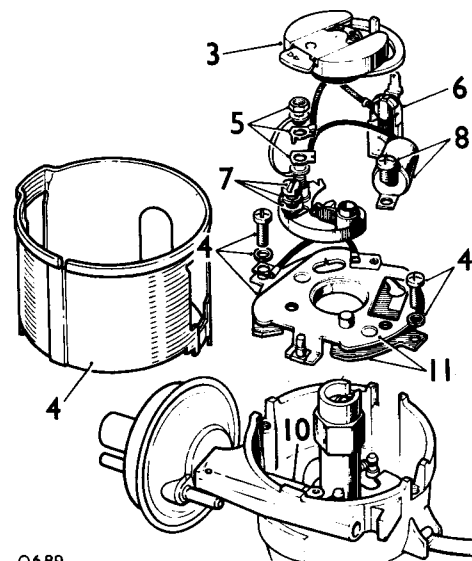

O689

- 12 If the distributor is the type with an external adjuster on the side of the body, remove the circlip, adjusting nut, coil spring and ratchet, and withdraw the vacuum unit.
- 13 If the distributor is the type that does not have an external adjuster, drive out the roll-pin from the distributor body and withdraw the vacuum unit.
- 14 Withdraw the springs from the centrifugal advance unit.
- 15 Remove the screw from inside the cam and withdraw the cam and cam foot, noting the position of the rotor arm slot in relation to the distributor driving dog for assembly purposes.
- 16 Remove the two weights.
- 17 Withdraw the 'O' ring seal and cork washer from the underside of the distributor.
- 18 Drive out the pin securing the driving dog and withdraw the dog and thrust washer.
- 19 Remove the action plate and shaft.
- 20 Withdraw the distance collar.
- 21 Remove the clamping plate and exhaust heat shield.

#### Reassembling

- 22 Lightly smear the shaft, weight pivots and working surfaces of the weights, action cams and action plate with Rocol 'Moly Pad'.
- 23 Ensure that the drive shaft rotates freely in the bush without side play, otherwise fit a new distributor complete.
- 24 Reassemble by reversing the removal procedure noting the following:
- 25 Do not overstretch the governor spring during refitting.
- 26 When fitted, adjust the contact points gap to 0,35 mm to 0,40 mm (0.014 to 0.016 in.).

**NOTE:** The rotor arm is a special speed limiter type.

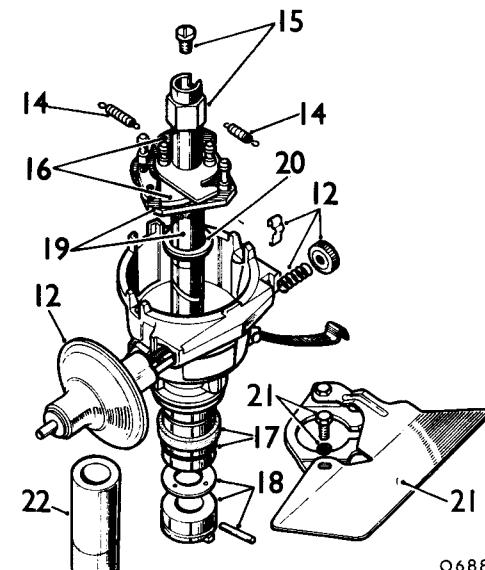

O688

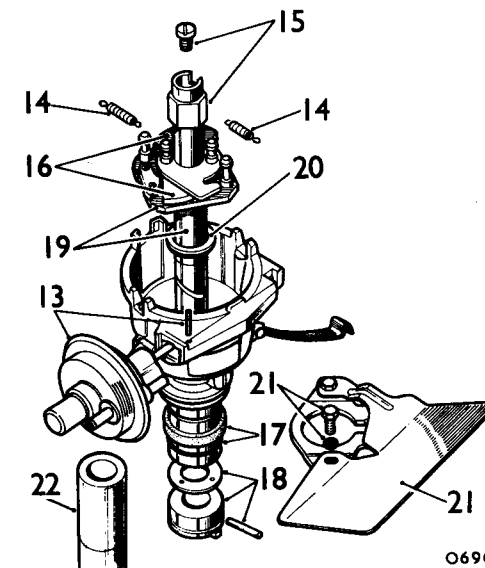

O690

## IGNITION COIL

Remove and refit

86.35.32

### Removing

- 1 Disconnect the battery.
- 2 Disconnect the high tension and low tension leads from the coil.
- 3 Remove the coil securing bolts.
- 4 Remove the coil.

### Refitting

- 5 Reverse instructions 1 to 4.

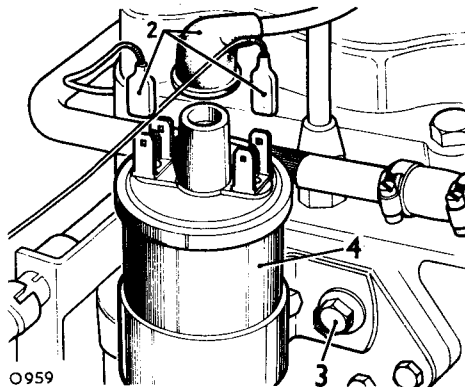

## FRONT SIDE AND FLASHER LAMPS

Remove and refit  
Front side lamp  
Front flasher lamp

86.40.34  
86.40.42

### Removing

- 1 Disconnect the battery.
- 2 Remove the lamp lens.
- 3 If required, remove the bulb.
- 4 Disconnect the lamp leads at the snap connectors in the engine compartment.
- 5 Remove the lamp body.

### Refitting

- 6 Reverse instructions 1 to 5.

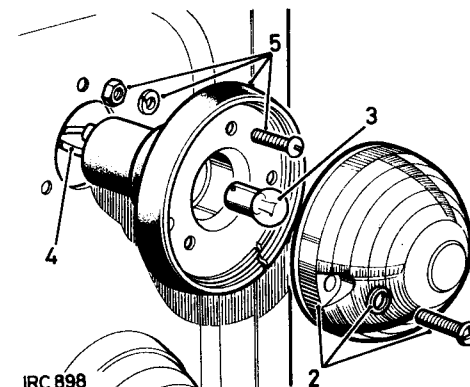

## HEADLAMP ASSEMBLY

Remove and refit

86.40.02

### Removing

- 1 Disconnect the battery.
- 2 Remove the headlamp bezel.
- 3 Remove the headlamp rim.
- 4 Disconnect the headlamp leads at the plug connector and withdraw the light unit.
- 5 Disconnect the spring from the headlamp shell.
- 6 Withdraw the headlamp shell by rotating it clear of the slotted locations.
- 7 Disconnect the headlamp leads at the snap connectors behind the radiator grille.
- 8 Remove the headlamp mounting shell.
- 9 Withdraw the gasket.

### Refitting

- 10 Reverse instructions 1 to 9.
- 11 Check, and if necessary adjust, the headlamp, using suitable beam setting equipment.

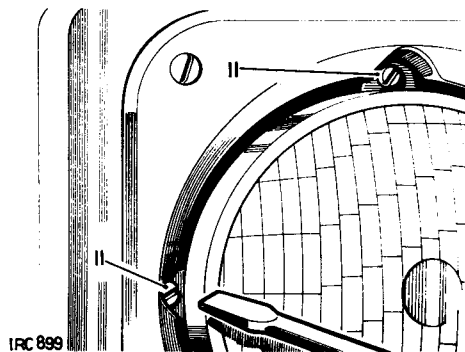
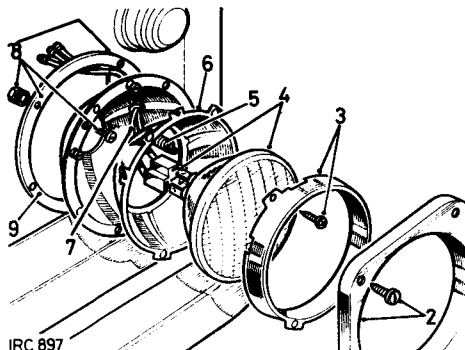

## REAR FLASHER AND TAIL LAMPS

Remove and refit  
Rear flasher lamp  
Tail lamp

86.40.45  
86.40.79

### Removing

- 1 Disconnect the battery.
- 2 Remove the rear lamp cover plate from inside the vehicle.
- 3 Disconnect the lamp leads.
- 4 Remove the lamp lens.
- 5 If required, remove the bulb.
- 6 Remove the lamp body.
- 7 Withdraw the rubber mounting for the tail lamp.

### Refitting

- 8 Reverse instructions 1 to 7.

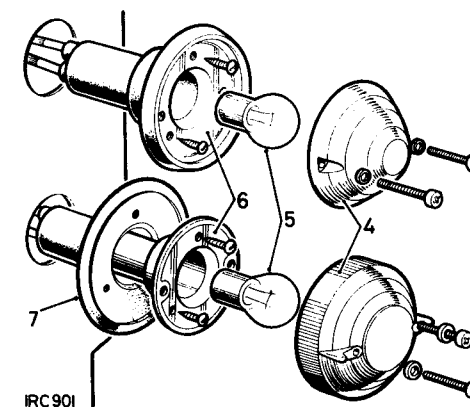
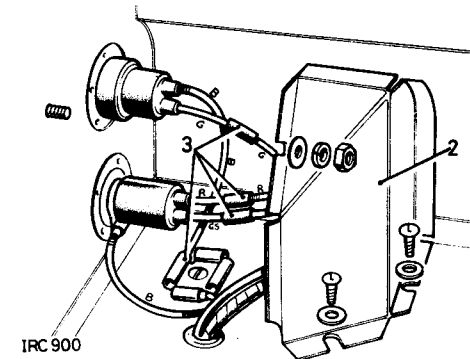

## PANEL ILLUMINATION LAMP OR WARNING LAMP BULB

Remove and refit

86.45.31

### Removing

- 1 Disconnect the battery.
- 2 Remove the two screws securing the instrument panels and ease the panel towards the steering wheel.
- 3 Withdraw the bulb holder and extract the bulb.

### Refitting

- 4 Reverse instructions 1 to 3.

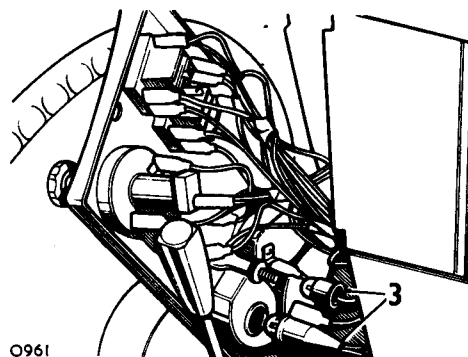
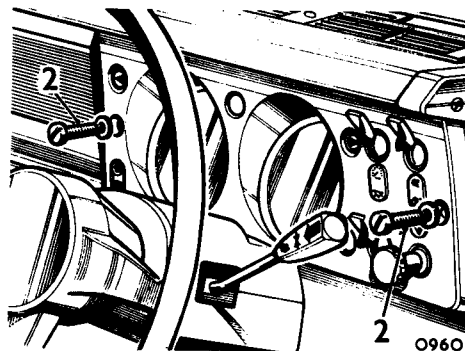

## INSPECTION SOCKET

Remove and refit

86.45.33

### Removing

- 1 Disconnect the battery.
- 2 Remove the two screws securing the instrument panel and ease the instrument panel towards the steering wheel.
- 3 Disconnect the electrical leads from the inspection socket.
- 4 Remove the screw lock rings, shock-proof washers and insulation tab.
- 5 Withdraw the sockets.

### Refitting

- 6 Reverse instructions 1 to 5. Ensure that the insulation tab is located to prevent bridging of the electrical leads.

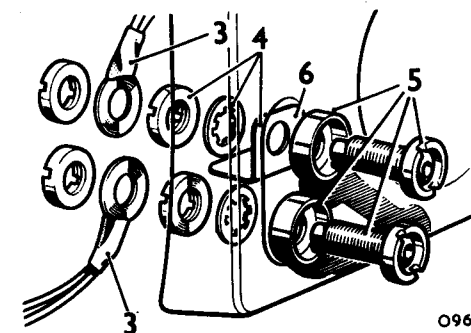

## FLASHER UNIT

Remove and refit

86.55.11

### Removing

- 1 Disconnect the battery.
- 2 Remove the two screws securing the instrument panel and ease the instrument panel towards the steering wheel.
- 3 Disconnect the electrical leads from the flasher unit.
- 4 Release the flasher unit from its retaining clip.

### Refitting

- 5 Reverse instructions 1 to 4.  
Lead Colours – Green to B terminal.  
Lead Colours – Light Green to L terminal.

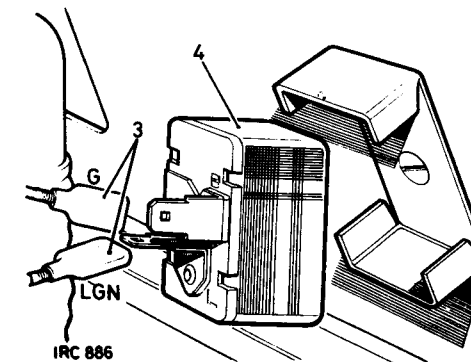

## STARTER MOTOR

Remove and refit

86.60.01

### Removing

- 1 Disconnect the battery.
- 2 Remove the exhaust manifold heat shield. (2¼ Petrol engine only)
- 3 Disconnect the electrical leads from the starter motor.
- 4 Remove the fixings securing the starter motor flange to the engine near mounting plate and bell housing.
- 5 Withdraw the starter motor. Note the earth cable fitting.

### Refitting

- 6 Reverse instructions 1 to 5.

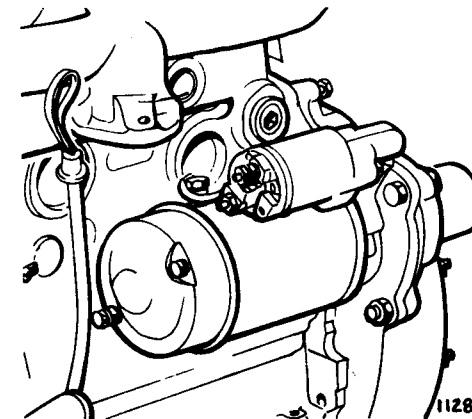
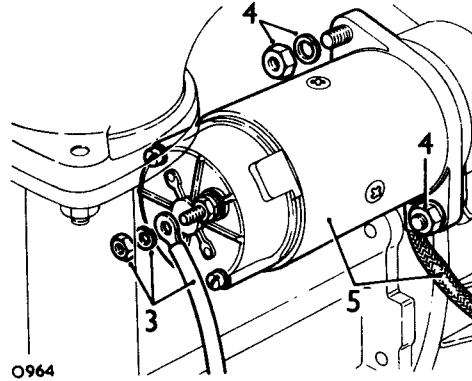
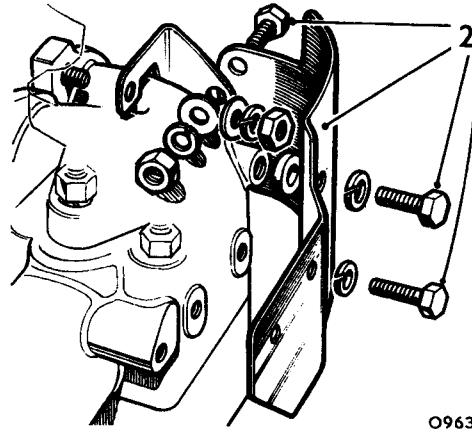

## STARTER SOLENOID – Petrol engines

Remove and refit

86.60.08

### Removing

- 1 Disconnect the battery.
- 2 Disconnect the solenoid/battery lead.
- 3 Disconnect the solenoid/starter motor lead.
- 4 Disconnect the ignition, solenoid switch and engine harness leads from the solenoid.
- 5 Remove the two bolts and nuts securing the solenoid. To facilitate access to the solenoid it may be found advantageous to remove the air cleaner (2¼ litre engines) or the battery (2.6 litre engines).
- 6 Remove the solenoid.

### Refitting

- 7 Reverse instructions 1 to 6.

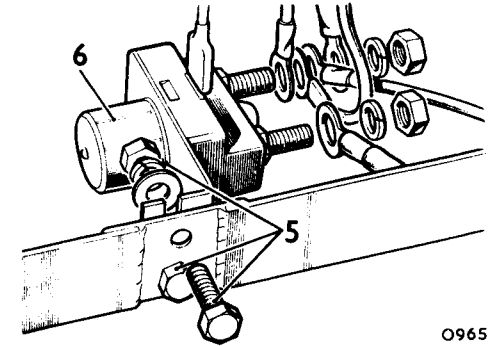

## STARTER MOTOR – Petrol engines

Overhaul

86.60.13

### Dismantling

- 1 Remove the starter motor. See 86.60.08.
- 2 Remove the through bolts.
- 3 Withdraw the commutator end cover from the yoke, disengage the field brushes from the brush box moulding, and remove the end cover.
- 4 Withdraw the yoke from the armature and drive end assembly.
- 5 Using a suitable clamp, clamp the end collar and compress the main spring.
- 6 Remove the circlip from the armature shaft.
- 7 Remove the clamp.
- 8 Withdraw the end collar, main spring, washer, screwed sleeve and pinion collar, pinion retaining spring and spring retaining sleeve.

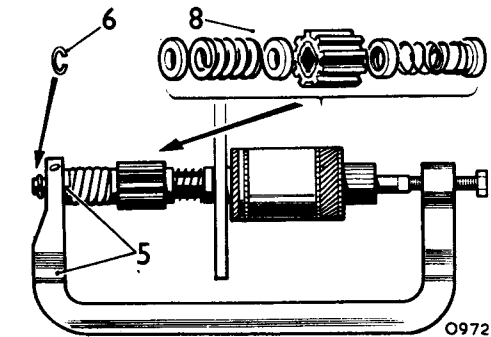

continued

**Inspection****Brushes**

- 9 Check that the brushes move freely in their holders. Any tendency to stick should be corrected by cleaning with a petrol moistened cloth, or in extreme cases by the light use of a fine file. Also ensure that the brush leads can move freely in the brush box slots. If a brush is damaged or worn so that it does not make good contact on the commutator, all the brushes must be renewed.
- 10 When brushes are worn to 9,5 mm (0.375 in.) length, new replacements must be fitted. The flexible connectors are soldered or crimped to terminal tags; two are connected to brush boxes, and two are connected to the free ends of the field coils. These flexible connectors must be removed by unsoldering, and the flexible connectors of the new brushes secured in their places by soldering. The new brushes, being pre-formed, 'bedding' to the commutator is unnecessary.

**Commutator end bracket**

- 11 Check the insulation of the brush springs by connecting a 110-volt a.c., 15-watt test lamp between a clean part of the commutator end cover and each of the springs in turn; the lamp will light if the insulation is not satisfactory.

**Commutator**

- 12 Clean the commutator with a petrol-moistened cloth. If necessary, rotate the armature and, using fine glass-cloth, remove pits and burned spots from commutator; remove abrasive dust with a dry air blast. If the commutator is badly worn, mount in a lathe, and, using a very sharp tool, take light cut, taking care not to remove more metal than is necessary. The insulators between the commutator segments must not be undercut.

**Armature**

- 13 If the armature is damaged, i.e. 'lifted' conductors, or distorted shaft, a new replacement must be fitted. Never attempt to machine the armature core, or 'true' a distorted armature shaft.

**Insulation and continuity checks**

If inspection of the armature and field coils of the starter motor do not reveal any faults, it is recommended that the following checks are carried out.

**Armature insulation**

- 14 Attach an ohm meter or a 110-volt AC test lamp in series with a 110-volt supply.
- 15 With two probes attached to the leads check the armature insulation by touching each commutator segment in turn with the other probe attached to the armature shaft.
- 16 The test lamp should not light up, or if an ohm meter is used, a high reading should be recorded. Should this not be the case, the armature insulation is faulty and a new replacement armature should be fitted.

**Armature continuity**

- 17 Indication of an open circuited armature winding will be given by burned commutator segments, this can be confirmed by substitution.

**Field coil continuity**

- 18 Check by connecting a 12-volt battery-operated test lamp between either of the brushes and a clean part of the yoke. The lamp should light.

**Field coil insulation:**

- 19 Before being able to check the insulation between the field coils and yoke, it will first be necessary to disconnect the earthed end of the winding from the yoke. Before disconnecting the winding (refer to the heading 'Renewing the field coils'), determine whether it is justified. Consider the results of

*continued*

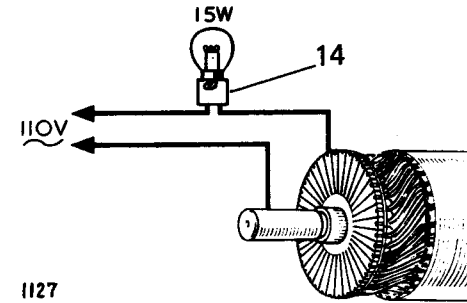

1127

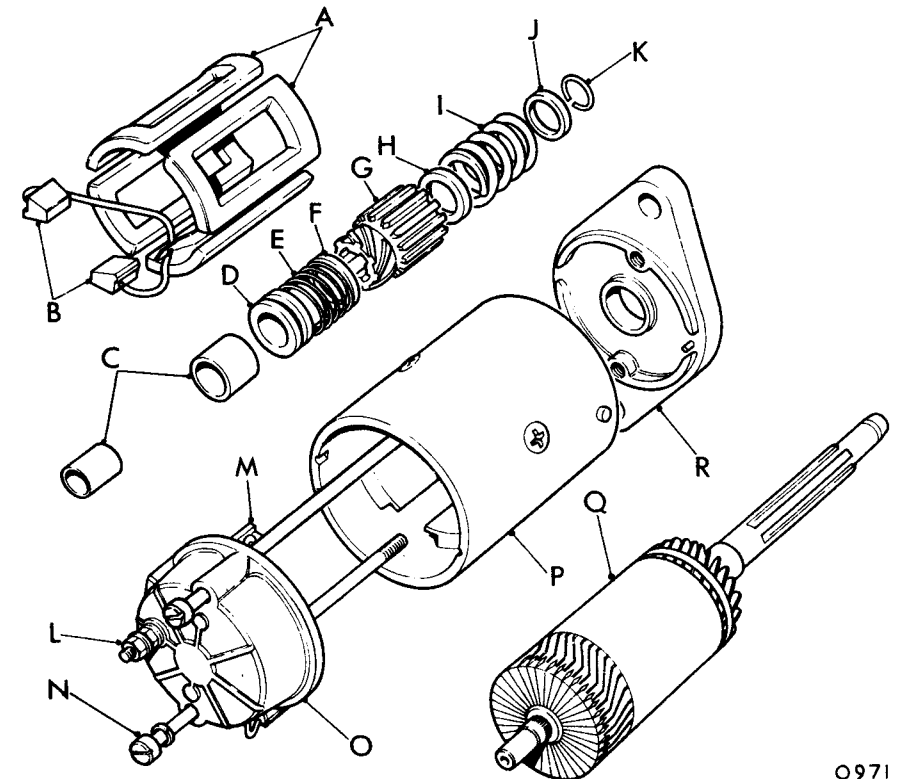
**KEY**

- A Field coils
- B Field coil brushes
- C Bearing brushes
- D Spring retaining sleeve
- E Spring
- F Pinion collar
- G Pinion and screwed sleeve
- H Washer
- I Main spring
- J End Collar
- K Circlip
- L Field coil input terminal
- M Earth brushes
- N Commutator end cover and brush box assembly
- P Yoke
- Q Armature
- R Drive end bracket

the light running and lock torque tests, or alternatively consider the fault symptoms. If the speed and torque were low, and the current consumption high, or the fault symptom was low cranking speed, faulty field winding insulation could be the cause and this interpretation of the starting motor performance would justify disconnecting the earthed end of the field winding to enable a positive check to be carried out.

- 20 The field winding insulation can be checked (after disconnecting the winding at the yoke) by connecting a 110-volt a.c. 15-watt test lamp between the disconnected end of the winding and a clean part of the yoke. **The lamp should not light.** Ensure that neither of the brushes, or bare parts of their flexibles, contact the yoke during the test.

**NOTE:** Due to the very low resistance of the field coil conductors, the presence of a short-circuit between the field coil windings can only be determined by specialised equipment. If the results of all previous testing has been satisfactory, short-circuited field coil windings could be the cause of the fault and the field coil assembly should now be further proved by substitution.

#### Renewing the field coils

- 21 Disconnect the end of the field winding where it is riveted to the yoke. To do this, file away the riveted-over end of the connecting-eyelet securing rivet, sufficient to enable the rivet to be tapped out of the yoke. Remove the four pole-shoe screws with a wheel-operated or power-operated screwdriver and withdraw the field coil assembly from the yoke. Wipe clean the inside of the yoke, and the insulating pieces through which the through bolts locate.
- 22 Loosely fit the new field coil assembly (with pole-shoes) into the yoke, with the threads of the pole-shoe fixing screws only partially engaged. The through bolt insulating pieces should now be assembled into the yoke, by sliding the shoulders of the insulating

pieces between the field coils and the yoke, in a position 180° apart and 90° each side of the field coil brush connection point (refer Fig. 4). Now tighten the pole-shoe screws progressively to a torque of 30 lbf ft (2.64 kgf m). Finally, make a good earth connection between the end of the field winding and the yoke.

#### Bearings

- 23 If the bearings in the commutator end cover and the drive-end bracket are worn sufficiently to allow excessive side-play of the armature shaft, the bearing bush must be renewed.

**NOTE:** New bushes must be immersed in new engine oil for 24 hours or in oil heated to 100°C. (212°F) for two hours prior to fitting. The bushes must not be reamed after fitting.

#### Reassembling

- 24 Reverse instructions 5 to 8, use a suitable piece of steel tube with a tapered end to fit the circlip to the armature shaft.
- 25 Fit the starter yoke to the armature assembly, ensuring that the location peg on the drive end bracket fits into the recess on the yoke.
- 26 Locate the field coil brushes into the brush box.
- 27 Fit the commutator end cover, ensuring that the earth brush leads do not become trapped between the end cover and the yoke.
- 28 Fit the two through bolts and spring washers. Torque 1,0 kgf. m. (8 lbf. ft.).
- 29 Fit the insulating washer, plain washer, spring washer and nut to the field coil input post.
- 30 Refit the starter motor.

#### DATA

##### Starter (2M100)

Brush spring tension .....	36 oz. (1,02 kg.)
Minimum brush length .....	0.375 in. (9,0 mm.)
Minimum commutator thickness .....	0.140 in. (3,5 mm.)
Lock torque .....	14.4 lb. ft. (2,02 kg. m.) with 463 amps.
Torque at 1,000 r.p.m. ....	7.3 lb. ft. (1,02 kg. m.) with 300 amps.
Light running current .....	40 amp at 6,000 r.p.m. (approx.)
Maximum armature end-float .....	0.010 in. (0,25 mm.)

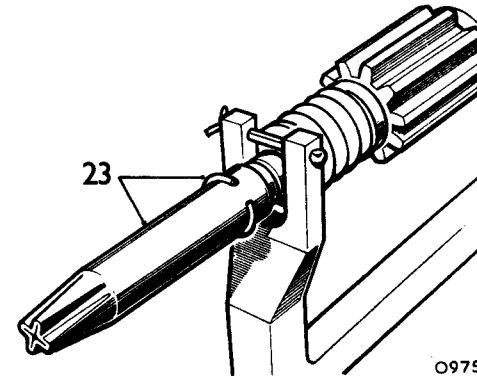

## STARTER MOTOR—2¼ litre Diesel engines

Overhaul

86.60.13

### Dismantling

- 1 Remove the starter motor. 86.60.08.
- 2 Remove the link connecting the solenoid to the starter motor yoke terminal.
- 3 Remove the solenoid from the drive end bracket.
- 4 Withdraw the gasket.
- 5 Grasp the solenoid plunger and lift the front end to release it from the top of the drive engagement lever.
- 6 Remove the block shaped sealing grommet wedged between the solenoid fixing part of the drive end bracket and the yoke.
- 7 Remove the commutator-end sealing cover.
- 8 Withdraw the seals.
- 9 Withdraw the field coil brushes from their holders.
- 10 Remove the commutator end bracket from the starter yoke.
- 11 Withdraw the yoke and field coil assembly.
- 12 Withdraw the sealing ring.
- 13 Remove the eccentric pin.
- 14 Withdraw the armature.
- 15 Withdraw the engagement lever.
- 16 Withdraw the seals for the through bolts.
- 17 Using a suitable tube, remove the collar and jump ring from the armature shaft.
- 18 Withdraw the drive assembly and intermediate bracket.
- 19 Remove the brake ring, steel washer and tufnol washer from the commutator end bracket.

*continued*

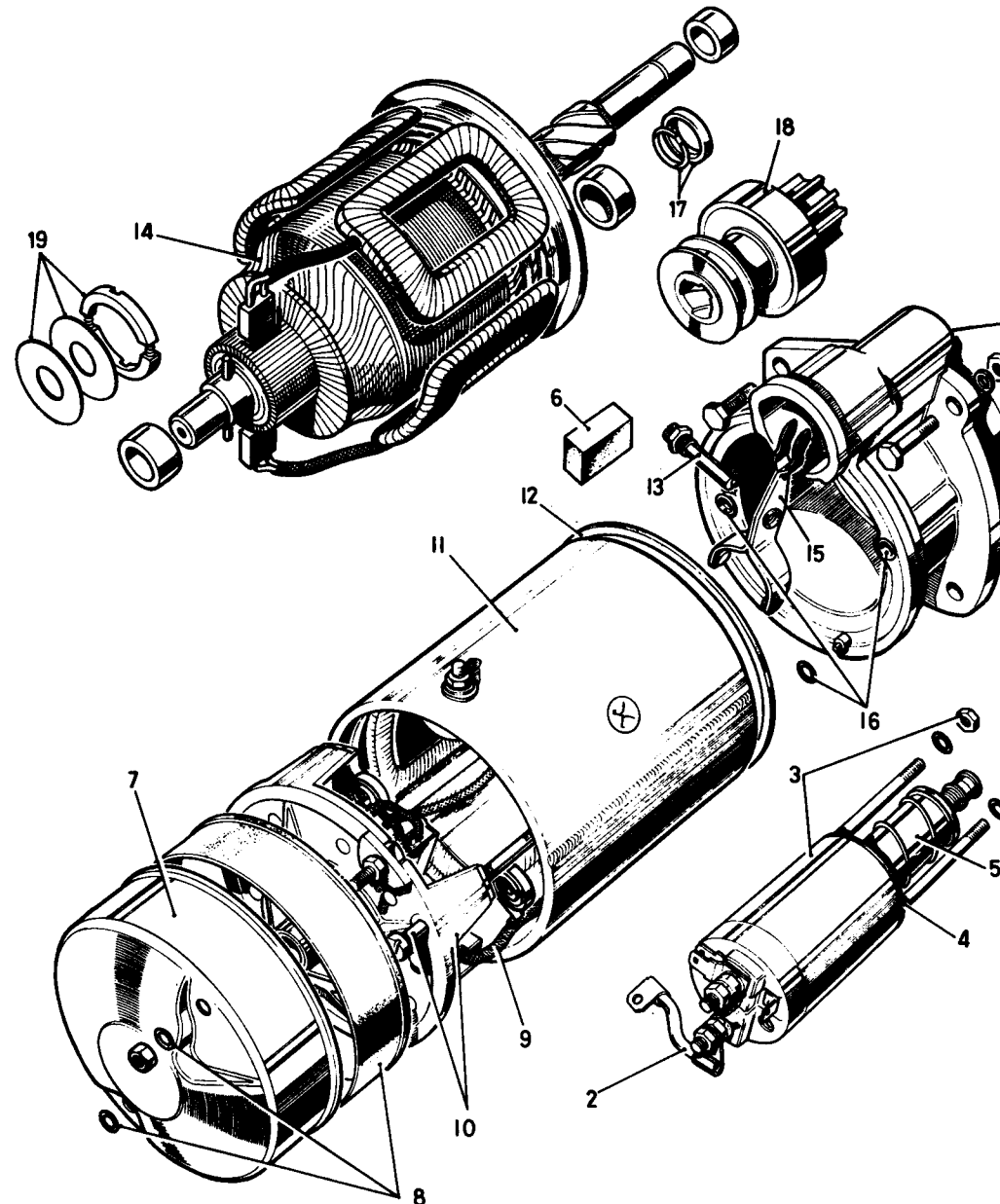



## Inspecting

### Clutch

- 20 Check that the clutch gives instantaneous take up of the drive in one direction and rotates easily and smoothly in the other direction.
- 21 Ensure that the clutch is free to move round and along the shaft splines without any tendency to bind.

**NOTE:** The roller clutch drive is sealed in a rolled steel outer cover and cannot be dismantled.

- 22 Lubricate all clutch moving parts with Shell SB 2628 grease for cold and temperate climates or Shell Retinax 'A' for hot climates.

### Brushes

- 23 Check that the brushes move freely in their holders while holding back the brush springs. Rectify sticking brushes by wiping with a petrol moistened cloth.
- 24 Fit new brushes if they are damaged or worn to approximately 8 mm (0.312 in.) in length.

**NOTE:** New brushes are pre-formed and do not require bedding to the commutator.

- 25 Check the brush box insulation by connecting a 110V a.c. 15W test lamp between a clean part of the bracket and each of the two insulated brush-boxes in turn. If the lamp lights, renew the commutator end bracket assembly.
- 26 Using a spring balance, check the brush spring pressure. With new brushes assembled in the bracket and the brushes contacting the commutator, the pressure should be approximately 1,2 kgf (42 ozf.). If the pressure is low, fit new springs.
- 27 Check the commutator. If cleaning only is necessary, use very fine glass paper or emery cloth, and then wipe the commutator surface with a petrol moistened cloth. If necessary, the commutator may be machined, providing a finished surface can be obtained without reducing the diameter below 38,0 mm (1.500 in.), otherwise a new armature must be fitted.

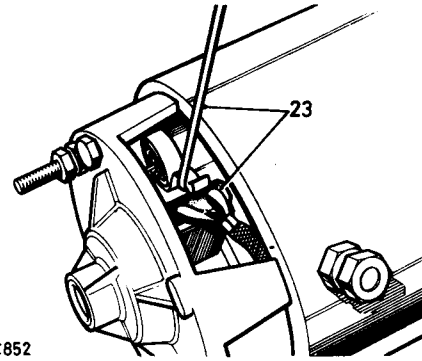

IRC852

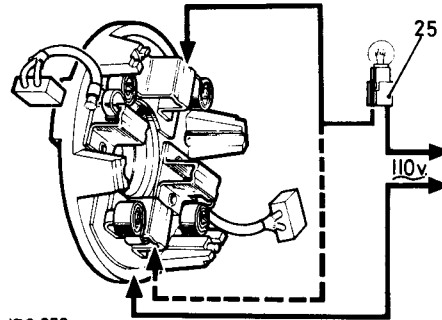

IRC 853

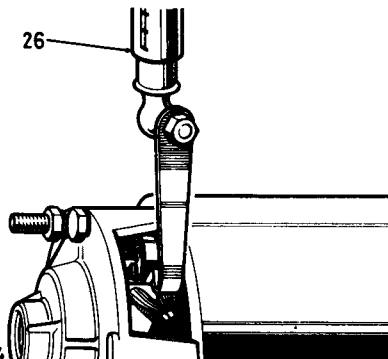

IRC854

### Armature insulation

- 28 Connect a 110V a.c. 15W test lamp between any one of the commutator segments and the shaft.
- 29 The lamp should not light, if it does light, fit a new armature.

### Field coil insulation

- 30 Connect a 110V a.c. 15W test lamp between the yoke terminal and the yoke.
- 31 Ensure that the brushes are not touching the yoke during the test.
- 32 The lamp should not light, if it does light, fit a new field coil assembly.

### Field coil continuity

- 33 Connect a 110V a.c. 15W test lamp between the two field coil brushes.
- 34 The lamp should light, if it does not light, fit a new field coil assembly.

### Solenoid

- 35 Disconnect all cables from the solenoid terminals and connectors.
- 36 Connect a 12V battery and a 12V 60W test lamp between the solenoid main terminals. The lamp should not light, if it does light, fit new solenoid contacts or a new solenoid complete.
- 37 Leave the test lamp connected and, using the same 12V battery supply, energise the solenoid by connecting 12V between the small solenoid operating 'Lucar' terminal blade and a good earth point on the solenoid body.
- 38 The solenoid should be heard to operate and the test lamp should light with full brilliance, otherwise fit new solenoid contacts or a new solenoid complete.

### Assembling

- 39 Reverse the dismantling procedure, noting the following.
- 40 Fit the drive engagement lever with the flatter edge towards the solenoid.
- 41 Leave the locknut for the eccentric pivot pin loose until the drive pinion setting has been adjusted.
- 42 Fit new seals and gasket.

*continued*

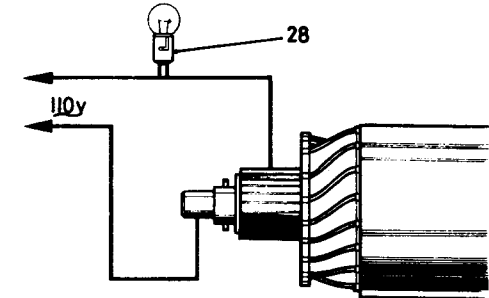

IRC 855

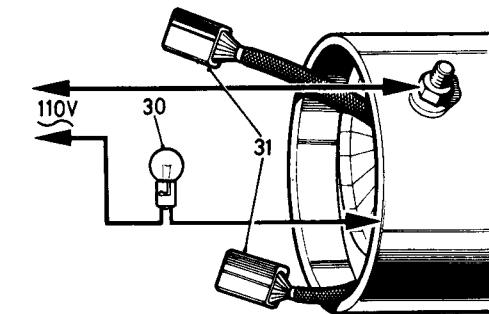

IRC 856

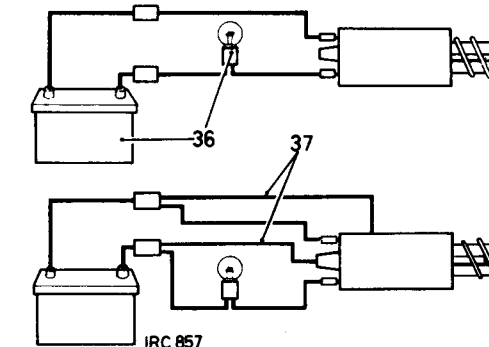

IRC 857

- 43 Torque tighten the solenoid fixing nuts 0,62 kgf. m (5.5 lbf. ft.).
- 44 Torque tighten the solenoid outer terminal nuts 0,41 kgf. m (3.0 lbf. ft.).
- 45 Torque tighten the yoke terminal outer nut 0,2 kgf. m (1.5 lbf. ft.).
- 46 Torque tighten the starter through bolts 1,1 kgf. m (8.0 lbf. ft.).
- 47 Torque tighten the earth stud nut 0,82 kgf. m (6.0 lbf. ft.).

#### Setting drive pinion

- 48 If fitted, remove the link connecting the solenoid to the starter motor yoke terminal.
- 49 Connect the solenoid terminal 'STA' to the starter yoke case (not to the starter terminals).
- 50 Connect a 6V supply between the solenoid-operating 'Lucar' terminal and the starter yoke case (not the starter terminals).
- 51 With the solenoid energised and the drive assembly in the engaged position, hold the pinion pressed lightly towards the armature to take up any free play in the engagement linkage.
- 52 Measure the clearance between the pinion and the thrust collar on the armature shaft. The correct clearance is 0,12 mm to 0,38 mm (0.005 in. to 0.015 in.).
- 53 If necessary, adjust the clearance by rotating the eccentric pivot pin.
- 54 Remove the connections from the solenoid and the starter yoke case.
- 55 Apply sealing compound to the threads of the eccentric pivot pin and secure the locknut. Torque 2.2 kgf. m (16.0 lbf. ft.).
- 56 Reverse 1 and 2.

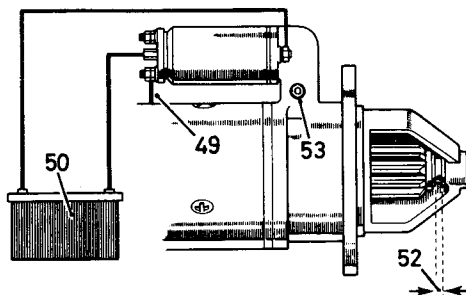

1RC859

#### DATA

##### Starter motor

Make/type	Lucas M45G Pre-engaged, oil and waterproof
Brush spring tension	1,2 kg (42 oz.)
Brush minimum length	8,0 mm (0.312 in.)

#### IGNITION/STARTER SWITCH – (Petrol engines) HEATER/STARTER SWITCH – (Diesel engines)

Remove and refit 86.65.02

##### Removing

- 1 Disconnect the battery.
- 2 Remove the steering column shroud.
- 3 Remove the lower fascia 76.46.05.
- 4 Disconnect the electrical leads from the ignition/starter switch.
- 5 Remove the two screws securing the switch to the steering column lock assembly.
- 6 Withdraw the ignition/starter switch.

##### Refitting

- 7 Reverse instructions 1 to 6.

##### Connect switch leads as follows:

##### Diesel engines

- Brown/red lead to terminal 1.
- White/red lead to terminal 2.
- White lead to terminal 3.
- Brown leads to terminal 4.

##### Petrol engines

- Brown leads to terminal 1.
- White leads to terminal 2.
- White/red lead to terminal 3.

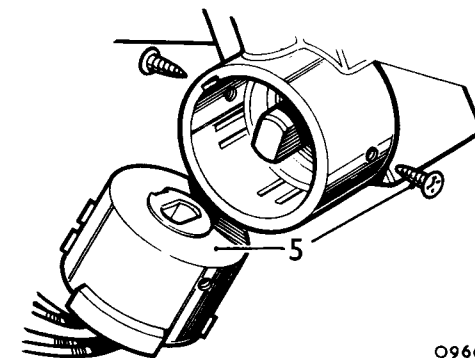

O966

## LIGHTING SWITCH

Remove and refit

86.65.10

### Removing

- 1 Disconnect the battery.
- 2 Unscrew and remove the locking ring and wave washer from the lighting switch.
- 3 Remove the two screws securing the instrument panel and ease the panel towards the steering wheel.
- 4 Disconnect the electrical leads from the rear of the lighting switch.
- 5 Withdraw the lighting switch.

### Refitting

- 6 Reverse instructions 1 to 5.

### Connect leads as follows:

- Red/black leads to terminal 1.
- Red lead to terminal 7.
- Brown lead to terminal 4.
- Blue lead to terminal 8.

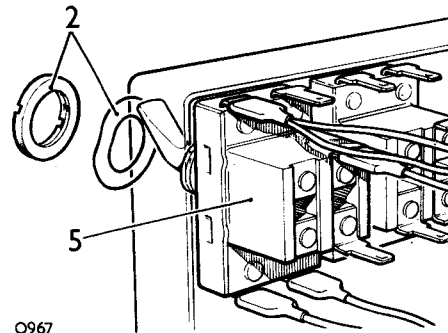

O967

## PANEL LIGHT SWITCH

Remove and refit

86.65.12

### Removing

- 1 Disconnect the battery.
- 2 Unscrew and remove the locking ring and wave washer from the panel light switch.
- 3 Remove the screws securing the instrument panel and ease the panel towards the steering wheel.
- 4 Disconnect the electrical leads from the rear of the panel light switch.
- 5 Withdraw the panel light switch.

### Refitting

- 6 Reverse instructions 1 to 5.

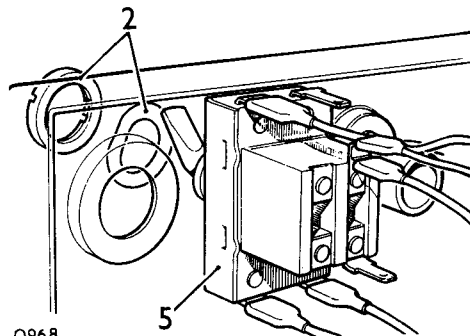

O968

## WINDSCREEN WIPER SWITCH

Remove and refit

86.65.38

### Removing

- 1 Disconnect the battery.
- 2 Depress the plunger retaining the wiper switch knob and withdraw the knob.
- 3 Unscrew and remove the lock ring and wave washer from the wiper switch.
- 4 Remove the screws securing the instrument panel and ease the panel towards the steering wheel.
- 5 Disconnect the electrical leads from the rear of the wiper switch.
- 6 Withdraw the wiper switch.

### Refitting

- 7 Reverse instructions 1 to 7.

### Connect leads as follows:

#### Petrol engines

- Light green/black to terminal 3.
- Red/light green to terminal 2.
- Green to terminal 4.
- Brown/light green to terminal 1.

#### Diesel engines

- Brown/light green to terminal 3.
- Red/light green to terminal 2.
- Green to terminal 4.
- Light green/black to unmarked terminal

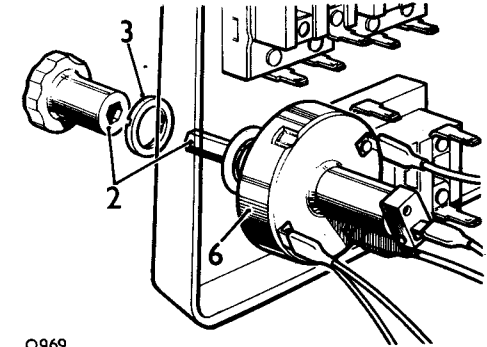

O969

**STOP LIGHT SWITCH**

Remove and refit

86.65.51

Non-servo models instructions 1 to 7

**Removing**

- 1 Disconnect the battery.
- 2 Remove the switch protection plate from the brake pedal bracket.
- 3 Disconnect the electrical leads from the switch.
- 4 Depress the brake pedal and remove the end stop from the switch and withdraw the switch from the mounting bracket.

**Refitting**

- 5 Reverse instructions 1 to 4.
- 6 Check the dimension between the lower edge of the brake pedal and the floor. The correct dimension is 158 mm (6.250 in.).
- 7 If necessary, set the brake pedal adjuster to give the correct dimension.

Servo-assisted models instructions 8 to 12

**Removing**

- 8 Disconnect the battery.
- 9 Disconnect the leads from the stop lamp switch.
- 10 Release the locknut and unscrew the switch from the brake pedal bracket.

**Refitting**

- 11 Reverse instructions 8 to 10.
- 12 Check, and if necessary adjust, the stop lamp switch to operate at 19 to 25 mm (0.750 to 1.000 in.) of pedal movement.

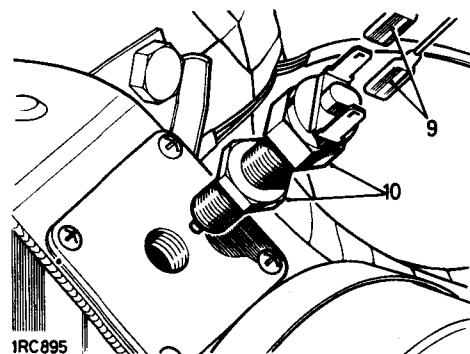
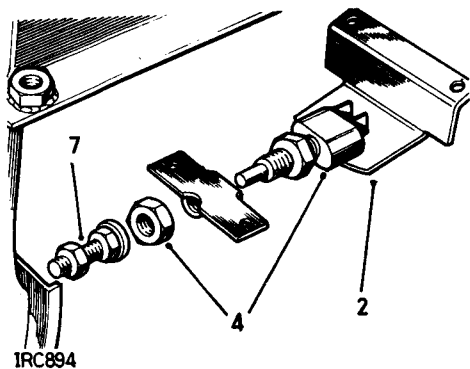
**CHOKE WARNING LIGHT SWITCH**

Remove and refit

86.65.53

**Removing**

- 1 Disconnect the battery.
- 2 Disconnect the electrical leads from the choke switch.
- 3 Release the clip securing the switch to the choke cable.
- 4 Remove the switch.

**Refitting**

- 5 Check that the choke inner cable is adjusted to provide a minimal clearance behind the knob when the knob is pushed in.
- 6 Check the switch to ensure that the spring loaded plunger projects and is free to move in the switch body.
- 7 Pull out the choke knob and locate the switch operating plunger in the centre hole in the sleeve of the choke outer cable; the two locating dowels engage in the outer holes.
- 8 Secure the switch in position and tighten the securing bolt and lock nut. Ensure the bolt is not overtightened to the extent where it will cause the plunger to jam.
- 9 Connect the switch leads.
- 10 Connect the battery.
- 11 Check switch and light operation.

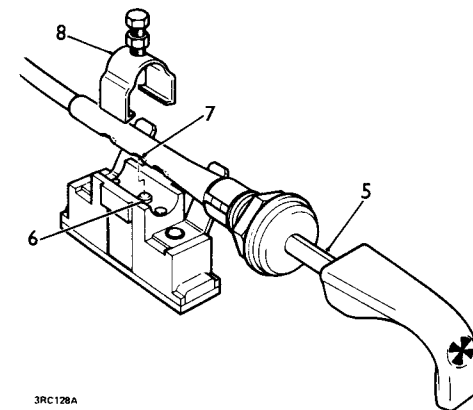

## COMBINED DIRECTION INDICATOR, HEADLIGHT AND HORN SWITCH

Remove and refit 86.65.55

### Removing

- 1 Disconnect the battery.
- 2 Remove the shroud from the steering column.
- 3 Remove the two screws securing the instrument panel and ease the panel towards the steering wheel.
- 4 Disconnect the switch harness block from the main harness socket.
- 5 Disconnect the single Lucas connector from the main harness to the switch.
- 6 Disconnect the headlamp dip lead from the fuse box.
- 7 Disconnect the lead to panel light switch.
- 8 Disconnect the lead to the voltage stabiliser.
- 9 Remove the screws securing the switch clip to the steering column.
- 10 Remove the switch.

### Refitting

- 11 Reverse instructions 1 to 10.

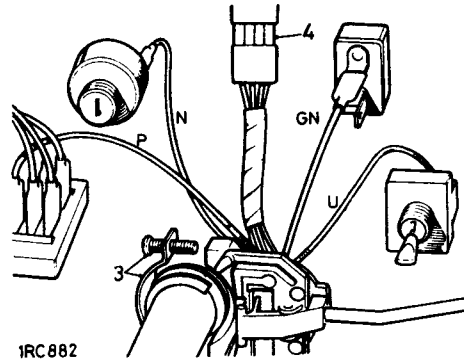

## FUSE BOX

Remove and refit 86.70.01

### Removing

- 1 Disconnect the battery.
- 2 Remove the steering column shroud.
- 3 Detach electrical connections from the fuse box terminals. Note the wiring colours and locations.
- 4 Remove the screws securing the fuse box.
- 5 Remove the fuse box.

### Refitting

- 6 Reverse instructions 1 to 5.
- NOTE:** All fuses should be 35 amp.

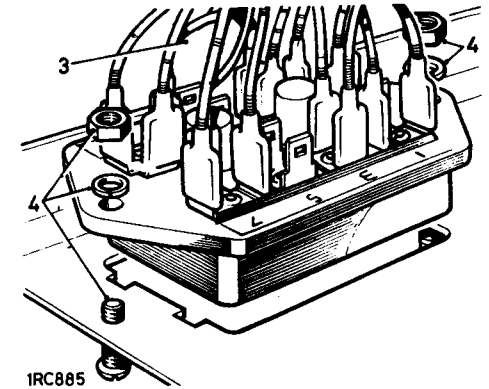

## INSTRUMENT PANEL

Remove and refit

88.20.01

### Removing

- 1 Disconnect the battery.
- 2 Remove the two screws securing the instrument panel to the fascia.
- 3 Withdraw the instrument panel towards the steering wheel.
- 4 Depress the clip on the speedometer cable and withdraw the cable from the speedometer.
- 5 Withdraw the bulb holders from the combined gauge cluster (2) and the speedometer (4).
- 6 Disconnect the terminals from the fuel and temperature gauges.
- 7 Disconnect the terminals from the voltage stabilizer.
- 8 Withdraw the bulb holders from the left and right hand turn indicators.
- 9 Disconnect the terminals from the lighting switch, panel light switch, wiper/washer and heater switch.
- 10 Disconnect the terminals from the inspection lamp socket (two circular slotted nuts).
- 11 Withdraw the instrument panel from the vehicle.

### Refitting

- 12 Slide the instrument panel into position between the steering wheel and the fascia.
- 13 Connect all terminals. Refer to illustration for locations and colour code.
- 14 Insert the bulb holders.
- 15 Connect the speedometer cable.
- 16 Fit the instrument panel to the fascia and secure in position with two screws.
- 17 Connect the battery.

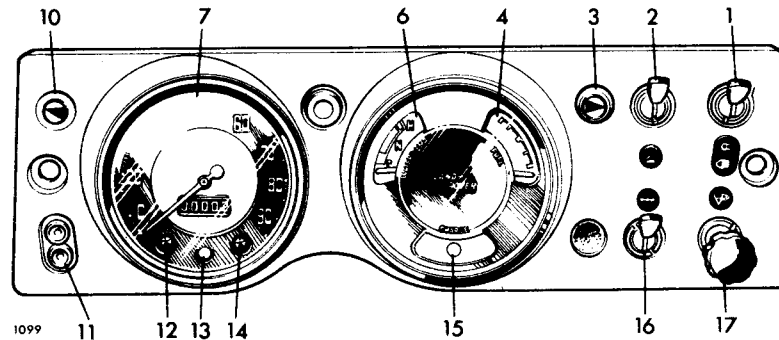

### Key to instrument panel

- 1 Side lamp/headlamp switch
- 2 Panel light switch
- 3 Direction indicator light -- right hand
- 4 Fuel gauge
- 5 Group instrument light
- 6 Water temperature gauge
- 7 Speedometer
- 8 Speedometer light
- 9 Voltage stabiliser
- 10 Direction indicator light -- left hand
- 11 Inspection lamp socket
- 12 Oil pressure light
- 13 Main beam indicator light
- 14 Choke indicator light
- 15 Ignition light
- 16 Heater switch
- 17 Wiper/washer switch

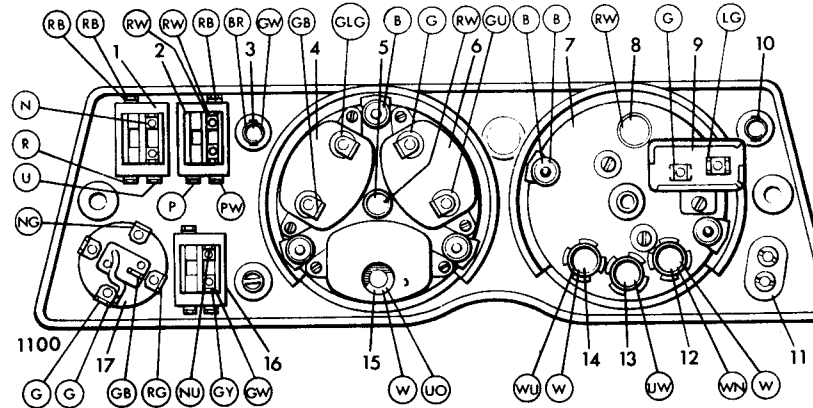

### KEY TO CABLE COLOURS

B	Black	G	Green	R	Red
U	Blue	O	Orange	W	White
N	Brown	P	Purple	L	Light
Y	Yellow				

**VOLTAGE STABILIZER**

Remove and refit

88.20.26

**Removing**

- 1 Disconnect the battery.
- 2 Remove the two screws securing the instrument panel to the fascia.
- 3 Withdraw the instrument panel towards the steering wheel.
- 4 Disconnect the terminals from the voltage stabilizer.
- 5 Remove the screw securing the voltage stabilizer to the speedometer.
- 6 Remove the voltage stabilizer.

**Refitting**

- 7 Fit the voltage stabilizer to the speedometer.
- 8 Connect the voltage stabilizer terminals.  
Green lead to terminal 'B'.  
Light green lead to terminal 'T'.
- 9 Fit the instrument panel to the fascia.
- 10 Connect the battery.

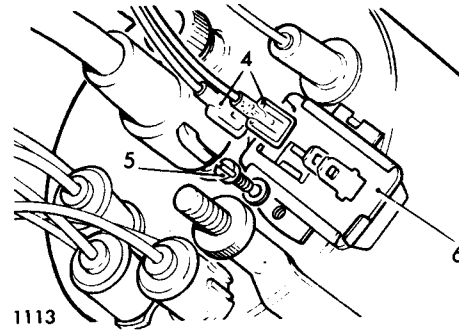

1113

**OIL PRESSURE WARNING SWITCH**

Remove and refit

88.25.08

- 2.6 litre engine, instructions 1 and 3 to 6.  
2½ litre engine, instructions 2 to 6.

**Removing**

- 1 2.6 litre engine. Locate the switch at the lower end of the rocker oil feed pipe, rear LH side of the engine.
- 2 2½ litre engine. Locate the switch at the oil filter, RH side of the engine.
- 3 Disconnect the electrical lead.
- 4 Unscrew the switch.
- 5 Withdraw the joint washer.

**Refitting**

- 6 Reverse 1 to 5 as applicable.

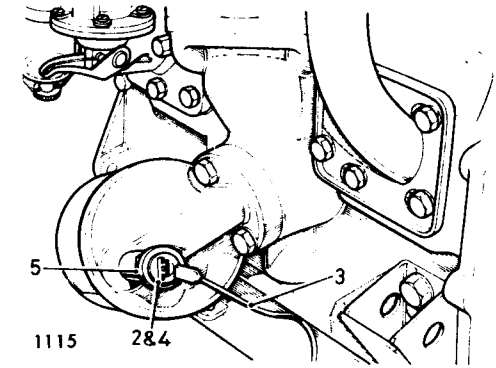

1115 284

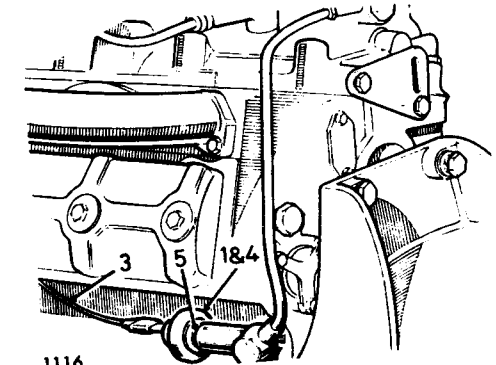

1116

## COOLANT TEMPERATURE GAUGE

Remove and refit

88.25.14

### Removing

- 1 Disconnect the battery.
- 2 Remove the two screws securing the instrument panel to the fascia.
- 3 Withdraw the instrument panel.
- 4 Withdraw the bulb holders (2) from the grouped gauge assembly.
- 5 Disconnect the terminals from the fuel gauge and temperature gauge.
- 6 Remove the three knurled nuts securing the grouped gauge assembly to the instrument panel.
- 7 Withdraw the three clamp brackets. Note the earth connection eyelet fitted to the top stud.
- 8 Withdraw the grouped instrument assembly.
- 9 Remove the two screws securing the temperature gauge and withdraw the temperature gauge.

### Refitting

- 10 Reverse instructions 1 to 9.

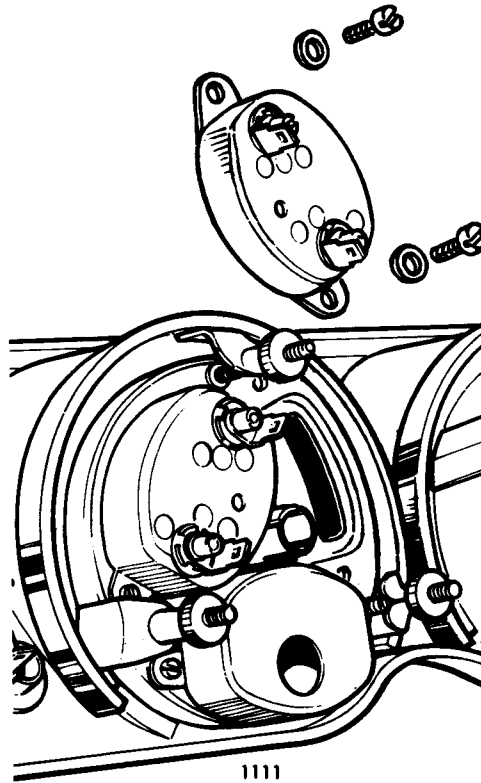

## COOLANT TEMPERATURE TRANSMITTER

Remove and refit

88.25.20

### Removing

- 1 Partly drain the engine coolant.
- 2 Locate the transmitter at the cylinder head as follows:  
2.6 litre Petrol – at RH side forward of carburetter;  
2¼ litre Diesel – in adaptor at LH side rear, top;  
2¼ litre Petrol – in adaptor at RH side beneath thermostat housing.
- 3 Disconnect the electrical lead.
- 4 Remove the temperature transmitter.

### Refitting

- 5 Reverse instructions 1 to 4. Do not overtighten; check for coolant leakage after initial engine run.

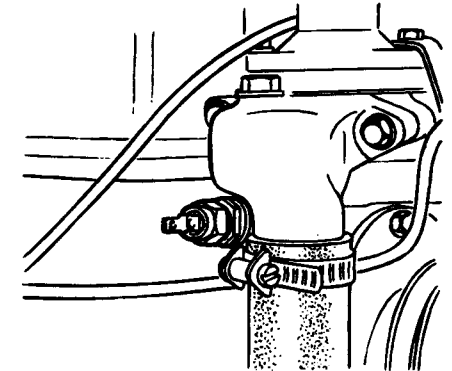

2¼ litre petrol engine

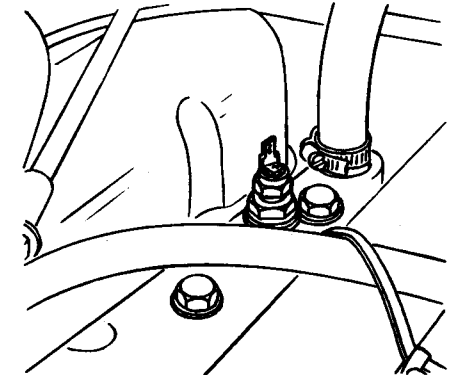

2¼ litre diesel engine

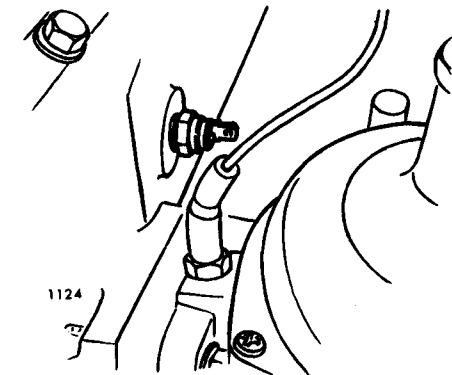

2.6 litre petrol engine



**FUEL GAUGE****Remove and refit****88.25.26****Removing**

- 1 Disconnect the battery.
- 2 Remove the two screws securing the instrument panel to the fascia.
- 3 Withdraw the instrument panel.
- 4 Withdraw the bulb holders (2) from the grouped gauge assembly.
- 5 Disconnect the terminals, from the fuel gauge and temperature gauge.
- 6 Remove the three knurled nuts securing the grouped gauge assembly to the instrument panel.
- 7 Withdraw the three clamp brackets. Note the earth connection eyelet fitted to the top stud.
- 8 Withdraw the grouped instrument assembly.
- 9 Remove the two screws securing the fuel gauge and withdraw the fuel gauge.

**Refitting**

- 10 Reverse instructions 1 to 9.

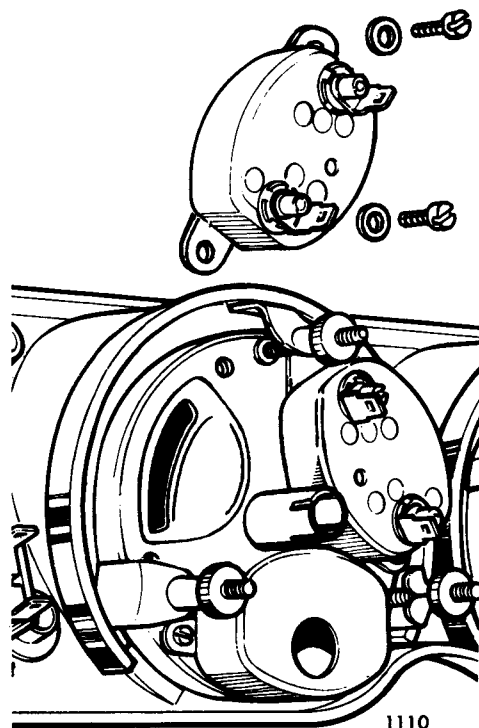
**FUEL TANK GAUGE UNIT (Rear mounted tank)****Remove and refit****88.25.32****Removing**

- 1 Disconnect the battery.
- 2 Remove the inspection cover in the rear floor.
- 3 Mark the gauge unit position in relation to the tank.
- 4 Disconnect the electrical feed lead.
- 5 Disconnect the earth lead at the gauge fixing.
- 6 Remove the retaining fixings and withdraw the gauge unit.

**Refitting**

- 7 Fit the gauge unit, using a suitable fuel resistant jointing compound ('Osotite' or similar) on the new joint washer.
- 8 Reverse instructions 1 to 5.

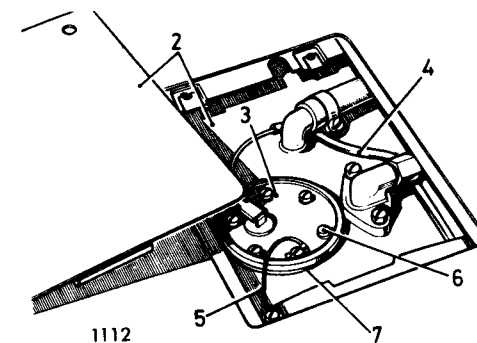
**FUEL TANK GAUGE UNIT (Side mounted tank)****Remove and refit****88.25.32****Removing**

- 1 Disconnect the battery.
- 2 Remove the RH seat cushion and tank cover panel.
- 3 Disconnect the electrical lead(s) at the gauge unit.
- 4 Mark the gauge unit position in relation to the tank.
- 5 Remove the fixings and withdraw the gauge unit.

**Refitting**

- 6 Fit the gauge unit, using a suitable fuel resistant jointing compound ('Osotite' or similar) on the new joint washer.
- 7 Connect the electrical lead/s as follows:  
Green/black lead to connector T;  
white/green lead (vehicles with fuel level warning light only) to connector W;  
the gauge unit is earthed through the tank-to-chassis fixings.
- 8 Reverse instructions 1 to 3.

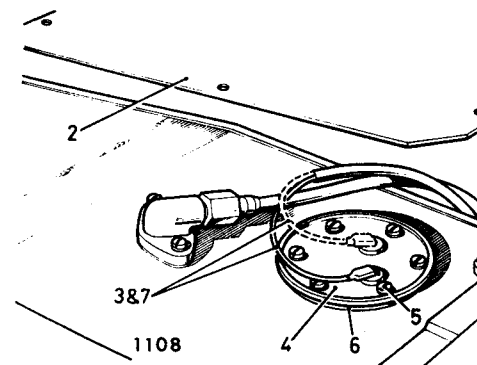

## SPEEDOMETER

Remove and refit

88.30.01

### Removing

- 1 Disconnect the battery.
- 2 Remove the two screws securing the instrument panel to the fascia and ease the panel clear of the fascia.
- 3 Depress the clip on the speedometer cable and withdraw the cable from the speedometer.
- 4 Withdraw the bulb holders (4) from the speedometer.
- 5 Disconnect the terminals from the voltage stabilizer.
- 6 Remove the two knurled nuts securing the speedometer to the instrument panel.
- 7 Release the three earth connections eyelets and remove the two clamp brackets.
- 8 Withdraw the speedometer.
- 9 Remove the voltage stabilizer.

### Refitting

- 10 Reverse instructions 1 to 9.

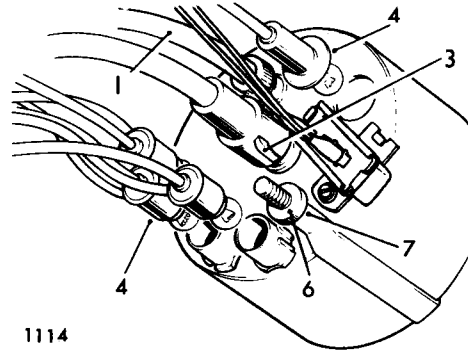

1114

## SPEEDOMETER CABLE

### Remove and refit

Cable complete, instructions 1, 2, 4, 5 and 6 88.30.06  
Inner cable, items instructions 1, 2, 3 and 6 88.30.07

### Removing

- 1 Withdraw the instrument panel and disconnect the speedometer cable. 88.20.01 (instructions 1 to 4).
- 2 Withdraw the speedometer cable end into the engine compartment.
- 3 Withdraw the inner cable from the outer.
- 4 Detach the speedometer cable grommets from the securing clips at the engine, flywheel housing, chassis side-member and transfer gearbox.
- 5 Disconnect the cable at the gearbox.

### Refitting

- 6 Reverse items 1 to 5 as applicable. When replacing the inner cable, grease sparingly with general purpose grease. Ensure that the inner cable is engaged in the drive slot at the gearbox.

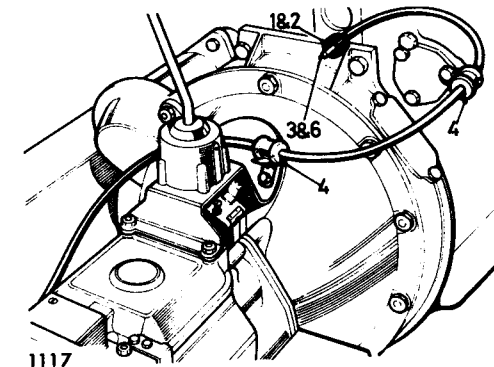

1117

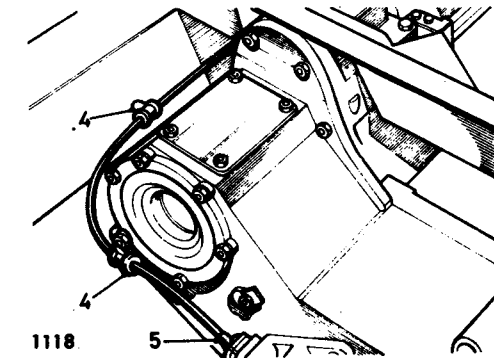

1118



## SERVICE TOOLS

### ENGINE

- 246650. Cylinder liner press block (2.6 Petrol)
- 261288. Reboring jig block (2.6 Petrol)
- 262749. Extractor—side rocker shaft (2.6 Petrol)
- 270304. Guide—rear bearing cap seals
- 271482. Injector cap spanner (2½ Diesel)
- 271483 (18G 109A). Test gauge—injector (2½ Diesel)
- 274389. Reamer—camshaft bearings (2½ Engines)
- 274399. Drift—push rod tube and injector shroud (2½ Diesel)
- 274400. Drift—inlet valve guide
- 274401. Drift—exhaust valve guide
- 276102. (18G 106). Valve spring compressor
- 278181. Injector—nozzle flushing tool (2½ Diesel)
- 278182. Injector—adaptor (2½ Diesel)
- 507231. Extractor—camshaft sprocket
- 530101. Extractor and puller
- 530101A. Extractor—tappet guide
- 530102. Spanner—starting dog and differential (three-bearing engine)
- 530102A. Spanner—starting dog and differential (three- and five-bearing engines)
- 530625. Adaptor—exhaust valve seats
- 600959. Drift—exhaust valve seats
- 600963. Engine sling

- 601508. Drift—inlet valve guides
- 605003. Injector nozzle cleaning wire
- 605052. Tool—removing immersion heater plug
- 605238. Plastigage
- 605863. Injection pump timing tool (2½ Diesel)
- 605975. Tool—remove/refit camshaft bearings (2½ Engines)
- 606445. Spanner—cylinder head (2½ Diesel)

### GEARBOX

- 243241. Protection cap—gearbox output shaft
- 600300. Spanner—mainshaft nut
- 605022. Mandrel—clutch centre plate
- 605862. Extractor—transfer box, intermediate shaft
- RO 1013. Torque adaptor—gearbox mainshaft nut

### STEERING

- 60000. Extractor—drop arm
- 600536. Compressing tool—steering relay spring
- 601763 (JD 24). Removal tool—steering ball joints

### AXLE

- 262757. Extractor—differential pinion bearing (Rover-type axle)
- 262757-1. Adaptor—pinion bearing cup replacer
- 262758. Press block—pinion bearing
- 275870. Bearing remover—axle shaft
- 530105. Spanner—differential (Rover-type axle)
- 530106. Bracket—dial indicator gauge
- 605004. Gauge—differential pinion (Rover-type axle)
- 606435. Spanner—hub nut
- 18G 47 BK. Adaptor—pinion bearing cone remover/replacer (Salisbury-type axle)
- 18G 47 BL. Adaptor—removing differential bearing cones (Salisbury-type axle)
- 18G 131 C. Spreader—differential case (Salisbury-type axle)
- 18G 131 F. Adaptor pins—axle spreader (Salisbury-type axle)
- 18G 134 DP. Adaptor—differential bearing replacer (Salisbury-type axle)
- 18G 191. Dial gauge, bracket and base
- 18G 191P. Pinion setting gauge (used with 18G 191)
- 18G 1122. Bearing cup replacer (Salisbury-type axle)
- 18G 1122G. Adaptor—pinion bearing cups (Salisbury-type axle)
- 18G 1205. Flange holding wrench
- 18G 1349. Hub oil seal replacer

RO 1008. Pinion oil seal replacer (Salisbury-type axle)

RO 1010. Spanner—front hub nut (109 Models)

S 123A. Pinion bearing cup remover

### BODY

262771. Filler strip tool

### GENERAL

- 47. Hand press
- 284. Impulse extractor
- 18G 134. Universal drift

**SERVICE TOOLS**

**ENGINE**

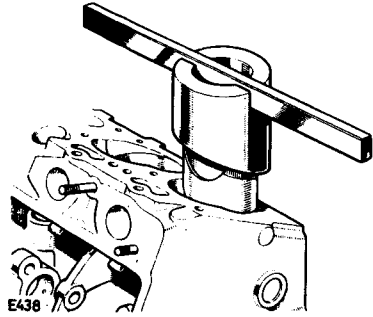

**246650. Cylinder liner press block (2.6 Petrol)**

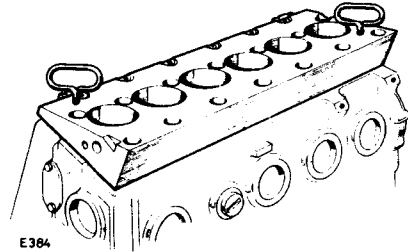

**261288. Reboring jig block (2.6 Petrol)**

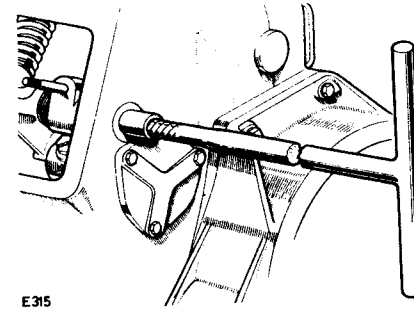

**262749. Extractor-side rocker shaft (2.6 Petrol)**

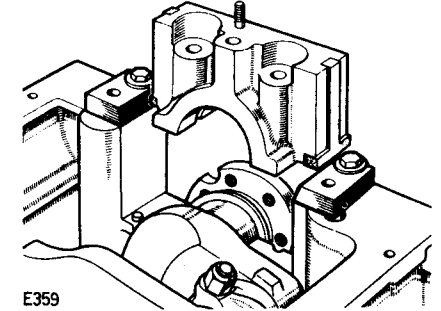

**270304. Guide-rear bearing cap seals**

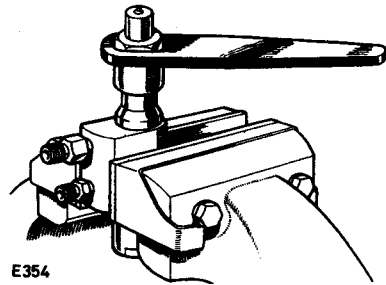

**271482. Injector cap spanner (2 1/4 Diesel)**

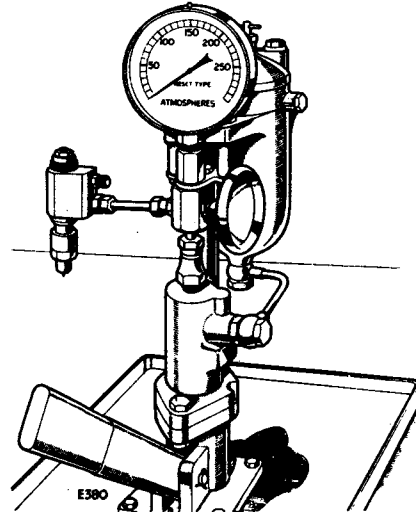

**271483 (18G 109A). Test gauge-injector (2 1/4 Diesel)**

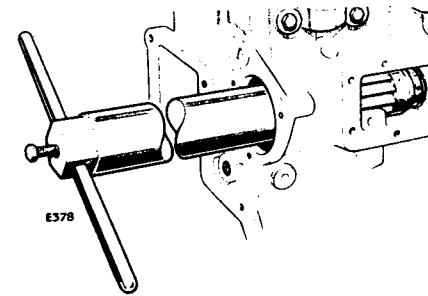

**274389. Reamer-camshaft bearings (2 1/4 Engines)**

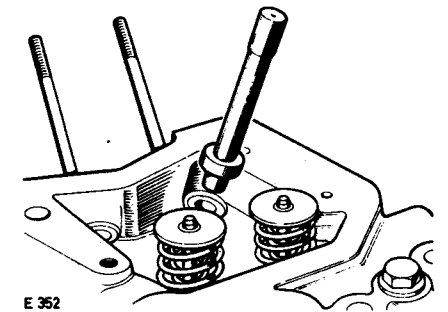

**274399. Drift-push rod tube and injector shroud (2 1/4 Diesel)**

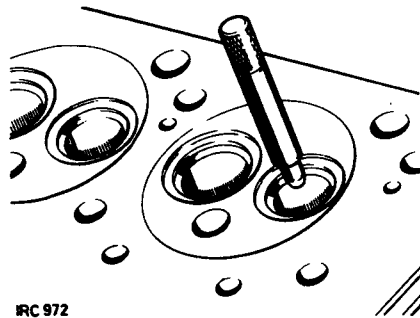

**274400. Drift-inlet valve guide**

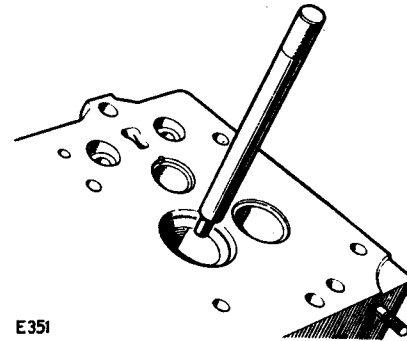

**274401. Drift-exhaust valve guide**

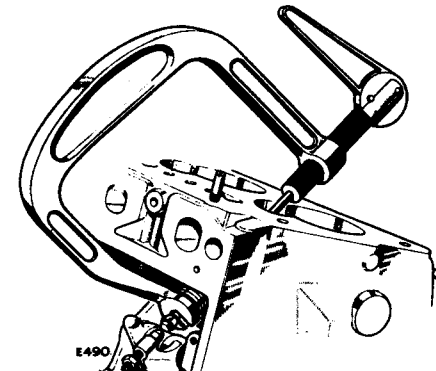

**276102 (18G 106). Valve spring compressor**

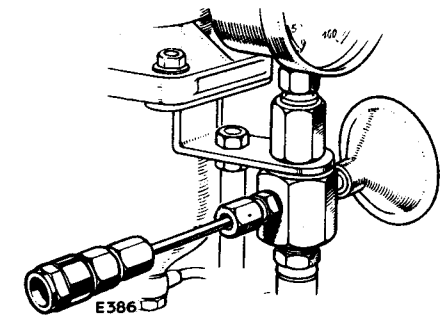

**278181. Injector-nozzle flushing tool (2 1/4 Diesel)**

*continued*

**ENGINE**

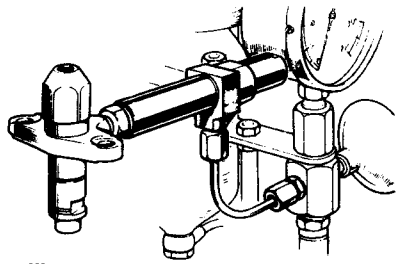

4RC987A

**278182. Injector—adaptor (2 1/4 Diesel)**

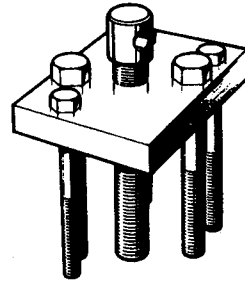

IRC 940

**507231. Extractor—camshaft sprocket**

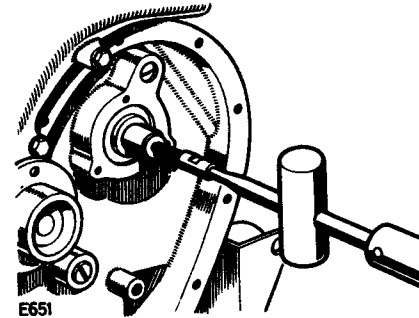

E651

**530101. Extractor and puller**

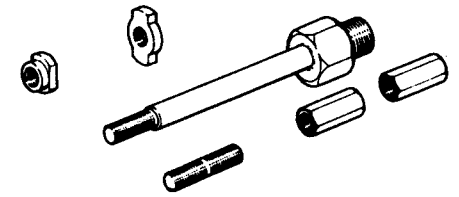

**530101A. Extractor—tappet guide**

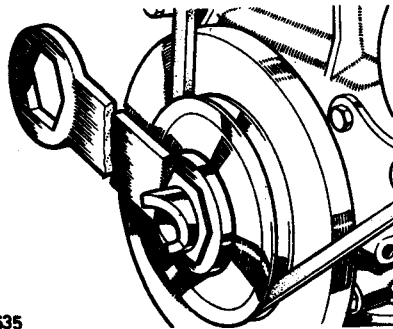

E635

**530102. Spanner—starting dog and differential**

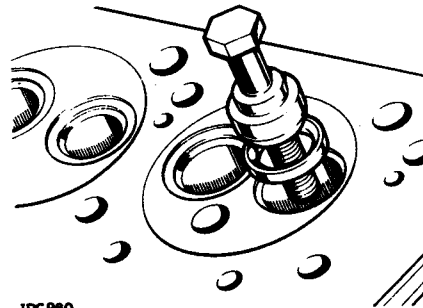

IRC980

**530625. Adaptor—exhaust valve seats**

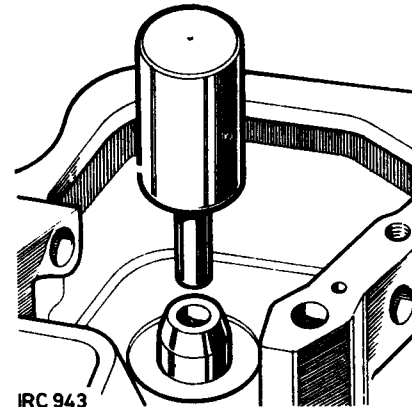

IRC 943

**600959. Drift—exhaust valve seats**

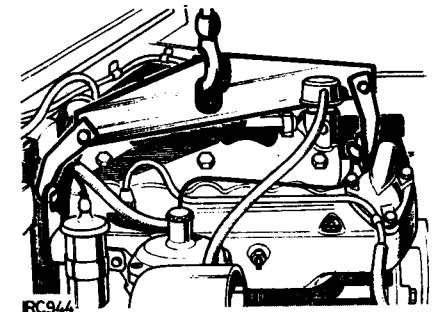

RC944

**600963. Engine sling**

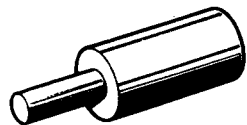

IRC 945

**601508. Drift—inlet valve guides**

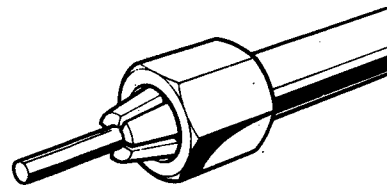

IRC947

**605003. Injector nozzle cleaning wire**

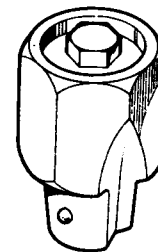

IRC 950

**605052. Tool—removing immersion heater plug**

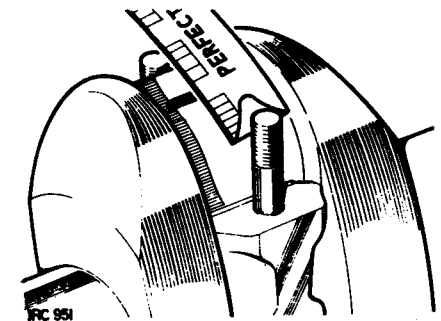

IRC 951

**605238. Plastigage**

*continued*

**ENGINE**

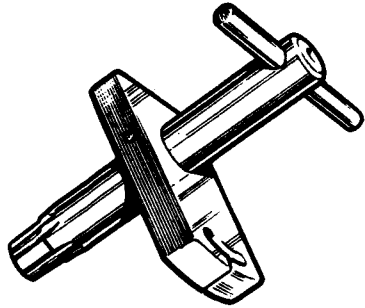

IRC 953

**605863. Injection pump timing tool (2 1/4 Diesel)**

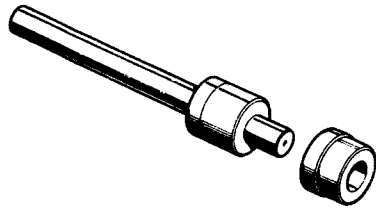

IRC 954

**605975. Tool—remove/refit camshaft bearings (2 1/4 Engines)**

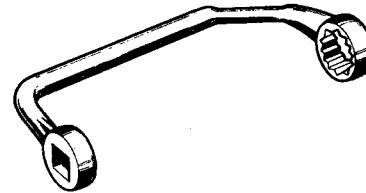

IRC 955

**606445. Spanner—cylinder head (2 1/4 Diesel)**

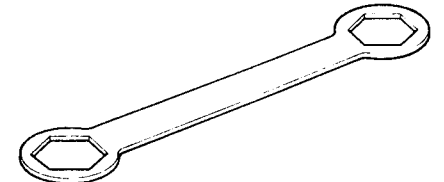

LR879

**530102A. Starting dog nut (three- and five-bearing engines)**

**GEARBOX**

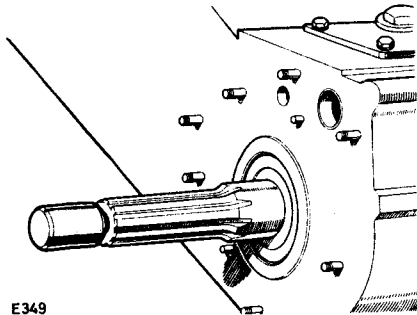

E349

**243241. Protection cap—gearbox output shaft**

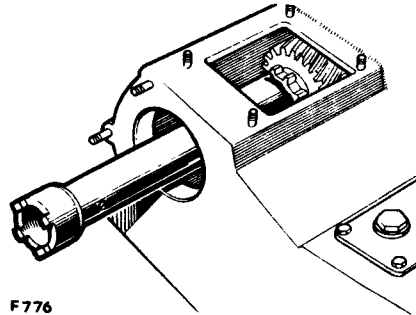

F776

**600300. Spanner—mainshaft nut**

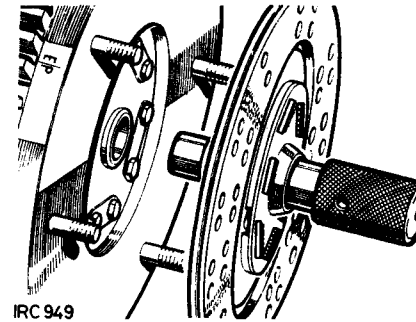

IRC 949

**605022. Mandrel—clutch centre plate**

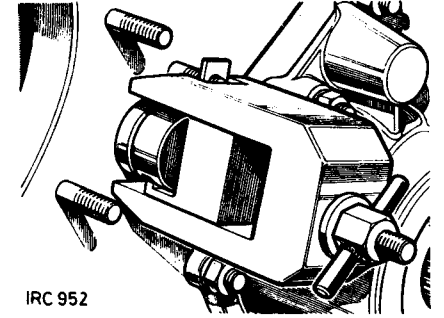

IRC 952

**605862. Extractor—transfer box, intermediate shaft**

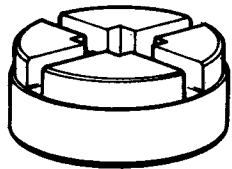

**RO 1013. Torque adaptor—gearbox mainshaft nut**

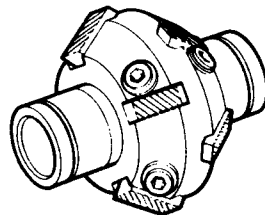

**MS 621, MS 627. Inlet and exhaust valve seat cutter**

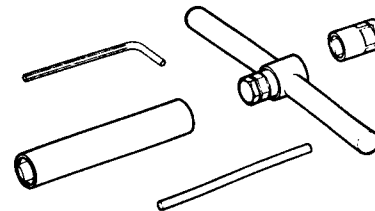

**MS 76. Cutter hand set**

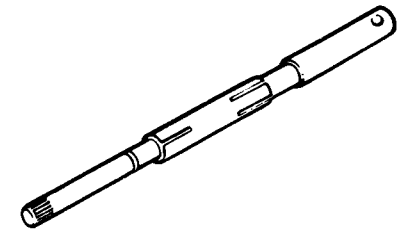

**MS 150-8, MS 150-8.5 Adjustable pilots**

**STEERING**

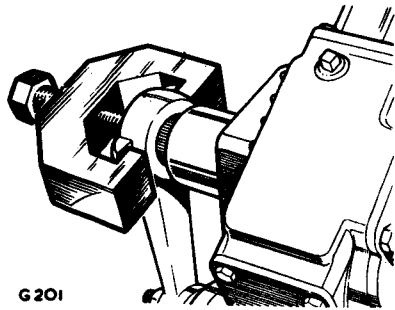

G201  
60000. Extractor—drop arm

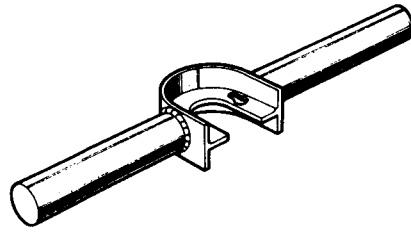

IRC 942  
600536. Compressing tool—steering relay spring

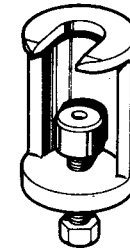

IRC 946  
601763 (JD 24). Removal tool—steering ball joints

**AXLE**

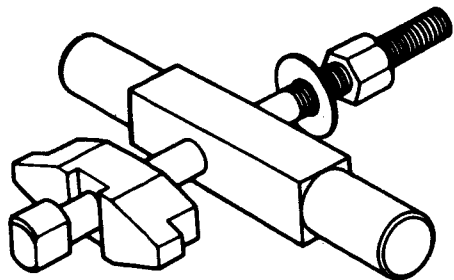

262757. Extractor—differential pinion bearing (Rover-type axle)

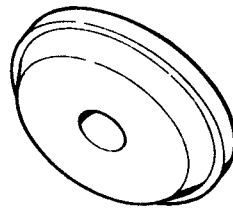

262757-1. Adaptor—pinion bearing cup replacer

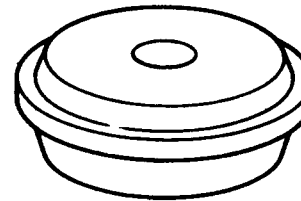

262758. Press block—pinion bearing

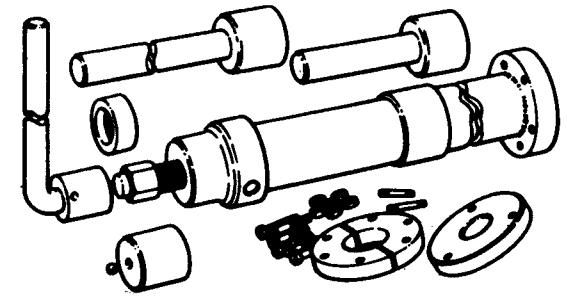

275870. Bearing remover—axle shaft



RC 941  
530105. Spanner—differential (Rover-type axle)

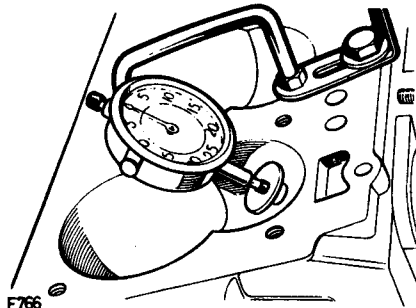

F766  
530106. Bracket—dial indicator gauge

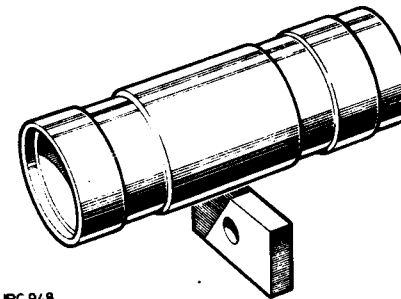

RC 948  
605004. Gauge—differential pinion (Rover-type axle)

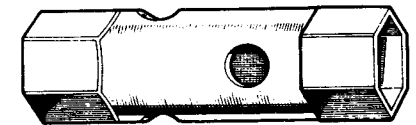

RC 956  
606435. Spanner—hub nut

*continued*



AXLE

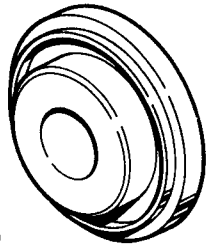

LR880

18G 1349. Hub oil seal replacer

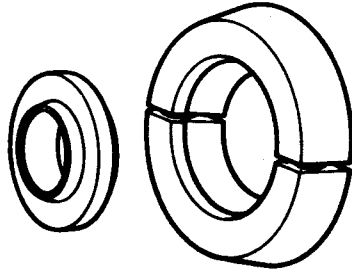

18G 47 BK. Adaptor-pinion bearing cone remover/replacer (Salisbury-type axle)

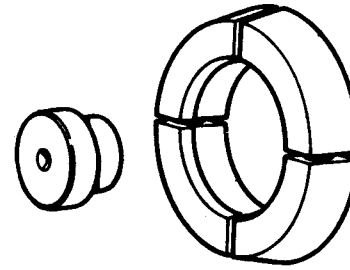

18G 47 BL. Adaptor-removing differential bearing cones (Salisbury-type axle)

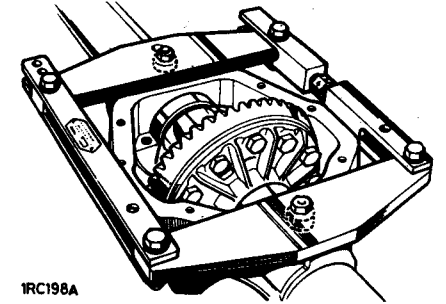

IRC198A

18G 131 C. Spreader-differential case (Salisbury-type axle)

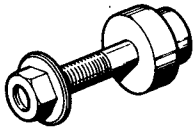

IRC 967

18G 131 F. Adaptor pins-axle spreader (Salisbury-type axle)

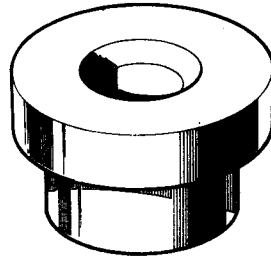

IRC 965

18G 134 DP. Adaptor-differential bearing replacer (Salisbury-type axle)

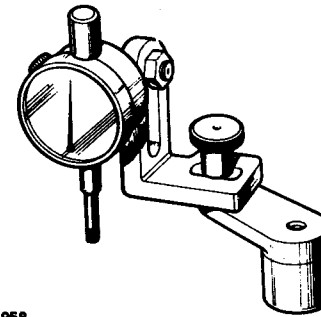

IRC 958

18G 191. Dial gauge, bracket and base

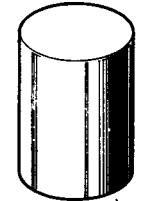

IRC 966

18G 191P. Pinion setting gauge (used with 18G 191)

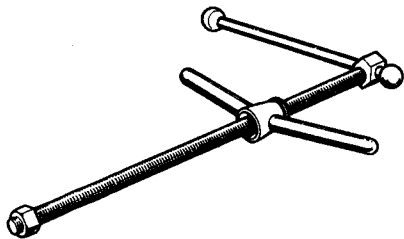

IRC 959

18G 1122. Bearing cup replacer (Salisbury-type axle)

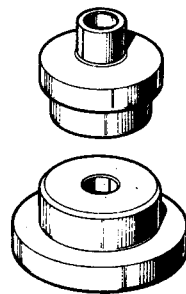

IRC 964

18G 1122G. Adaptor-pinion bearing cups (Salisbury-type axle)

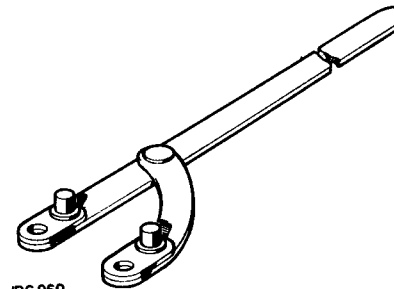

IRC 960

18G 1205. Flange holding wrench

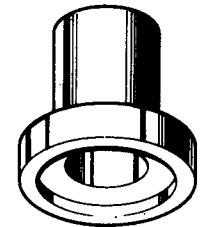

IRC 968

RO 1008. Pinion oil seal replacer (Salisbury-type axle)

continued

**AXLE**

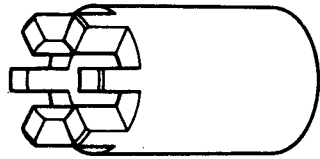

**RO 1010. Spanner—front hub nut (109 Models)**

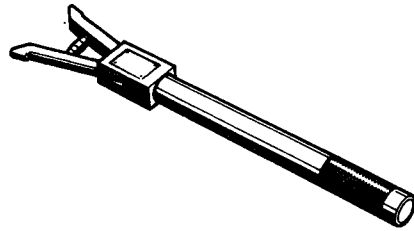

**IRC 96I**  
**S 123A. Pinion bearing cup remover**

**BODY**



**RC 938**  
**262771. Filler strip tool**

**GENERAL**

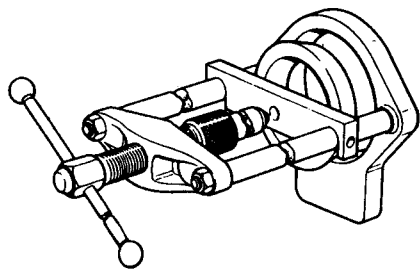

**47. Hand press**

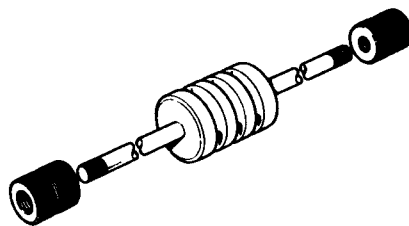

**284. Impulse extractor**

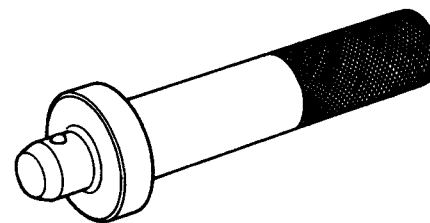

**18G 134. Universal drift**

From TIMAY AM 2014 P.

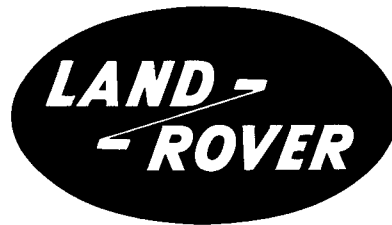

# **LAND ROVER**

## **Series III**

**FIVE MAIN BEARING ENGINE  
SUPPLEMENT**

## INTRODUCTION

This supplement must be used in conjunction with the current Land Rover Series III Repair Operation Manual.

The introduction of a five main bearing crankshaft to the 2¼ litre petrol and diesel engine has caused changes to some repair operations. The operations concerned have been revised and are included in this publication together with details of the differences between the new engines and the existing three bearing units.

Since the new petrol engine is manufactured at different plants, some variations exist and for purposes of identification two commencing serial numbers have been allocated namely 36100001A and 99100001A. The diesel engine commencing number is 36600001A.

Set out below are the principal differences between the three and five main bearing petrol engines and the variations between the two five main bearing units. Parts common to diesel engine serial number range 36600001A are also mentioned.

### Crankshaft

Redesigned to include five main bearings. The main bearing journal and crankpin dimensions remain the same as for the three bearing shaft. The five bearing shaft fitted to commencing serial number range 36100001A is a casting whereas a forged shaft is used in serial number range 99100001A and the diesel engine. Whilst a cast crankshaft must not be fitted to engines in serial range 99100001A and the diesel version a forged may be used in serial number range 36100001A. Forged crankshafts, however, will only be supplied for spares.

### Cylinder Block

Redesigned to accommodate five main bearings. Sealing of the rear main bearing changed to a lip type seal pressed into the flywheel housing. The outside diameter of the crankshaft flange runs in the seal. The relevant repair operations have been revised and included in this supplement.

### Camshaft

The valve timing of the camshaft fitted to the engine serial number range 36100001A is as follows.

Inlet opens	6° BTDC
Inlet closes	52° ABDC
Inlet peak	113° ATDC
Exhaust opens	34° BBDC
Exhaust closes	24° ATDC
Exhaust peak	95° BTDC

Number one exhaust cam peak is on the centre line of camshaft keyway.

The camshaft sprocket retaining bolt has a UNF thread.

Valve timing for the camshaft fitted to serial number range 99100001A and diesel engine number range 36600001A is:

Inlet opens	16° BTDC
Inlet closes	42° ABDC
Inlet peak	103° ATDC
Exhaust opens	51° BBDC
Exhaust closes	13° ATDC
Exhaust peak	109° BTDC

Number one exhaust cam peak on the camshaft fitted to serial number range 99100001A is 7° to the right of the keyway centre line viewed from the keyway end.

The camshaft sprocket retaining bolt has a metric thread.

### Oil Pump

Interchangeable as an assembly between serial number range 36100001A and 99100001A. The pump gears, although different, are interchangeable with either assembly provided the gears are fitted as a matched set. The pump is interchangeable on serial number range 36100001A. The idler gear and the driver are both steel on serial number range 99100001A. On serial number range 36100001A the idler is aluminium and the driver steel.

# INTRODUCTION

## Flywheel

Design change to fit five main bearing crankshaft flange. Interchangeable between serial number ranges 36100001A and 99100001A but not with diesel engine range 36600001A.

## Flywheel Housing

Design change to accommodate new crankshaft and rear main bearing oil seal arrangement. Interchangeable between serial number ranges 36100001A and 99100001A but not with diesel engine range 36600001A.

## Timing Chain Tensioner

The timing chain tensioner assembly is the same as used on the three main bearing versions. The assembly fitted to serial number range 99100001A is the same as that used on diesel engine range 36600001A. The tensioner fitted to early petrol engine range 36100001A has a different piston assembly incorporating a relief valve. This has now been discontinued and all three engines now have the same tensioner. The ratchet on serial number range 99100001A is different in appearance and method of manufacture but dimensionally the same.

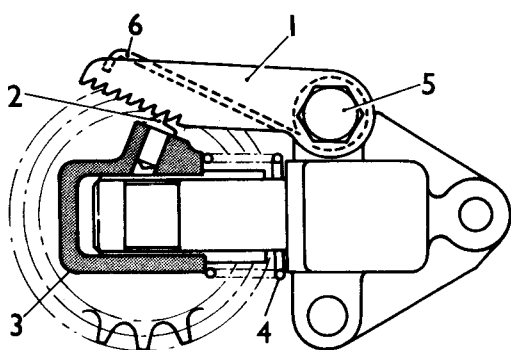

LR 667

**99100001A and 36600001A  
engine serial no. range**

1. Ratchet
2. Pawl
3. Cylinder
4. Spring
5. Ratchet pivot and retaining bolt
6. Ratchet return spring
7. Jockey sprocket
8. Retaining clip for ball
9. Ball

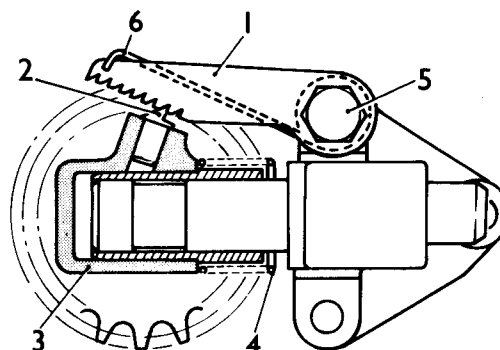

LR 666

**36100001A engine serial no. range  
(Early engines only)**

1. Ratchet
2. Pawl
3. Cylinder
4. Spring
5. Ratchet pivot and retaining bolt
6. Ratchet return spring
7. Jockey sprocket
8. Relief valve spring
9. Relief valve ball
10. Relief valve plug
11. Piston assembly

### **Ignition Distributor**

A Lucas type 45D4 with sliding contacts is fitted to engine serial number range 99100001A. Serial number range 36100001A is fitted with a Ducellier distributor.

Differences between the existing three main bearing diesel engine and the new five bearing unit serial number commencing 36600001A.

### **Cylinder Block**

Crankcase redesigned to accommodate the five main bearing crankshaft. Sealing of the rear main bearing changed to a lip type seal pressed into the flywheel housing. The outer diameter of the crankshaft flange runs in the seal.

### **Crankshaft**

Redesigned to include five main bearings. The main bearing journal and crankpin dimensions remain the same as the three bearing shaft.

### **Flywheel**

Modified to fit redesigned crankshaft flange.

### **Flywheel Housing**

Redesigned to accommodate new crankshaft rear main bearing oil seal arrangement.

### **Crankshaft Pulley**

Changed to a damper type pulley incorporating a band of rubber between the hub and pulley sections. Also dimensional changes.

### **Starter Dog**

Changed to that used on the five bearing petrol engines. Not interchangeable with the starter dog on the existing three bearing diesel engine.

### **Special Note**

When fitting a five main bearing engine as a replacement for a three bearing unit a new flywheel housing and seal must also be ordered.

CONTENTS

	Operation number	Page number
Introduction .....		01-1

**ENGINE OPERATIONS**

Crankshaft

– rear oil seal – remove and refit .....	12.21.20	12-3
– remove and refit .....	12.21.33	12-4

Flywheel

– remove and refit .....	12.53.07	12-8
--------------------------	----------	------

**FUEL SYSTEM OPERATIONS**

Fuel Injection Pump

– remove and refit .....	19.30.07	19-2
--------------------------	----------	------

**ELECTRICAL OPERATIONS**

Contact Breaker Points (Ducellier)

– remove and refit .....	86.35.13	86-2
--------------------------	----------	------

Contact Breaker Points (Lucas)

– remove and refit .....	86.35.13	86-3
--------------------------	----------	------

Distributor (Ducellier)

– overhaul .....	86.35.26	86-5
------------------	----------	------



# **ENGINE**

# **OPERATIONS**

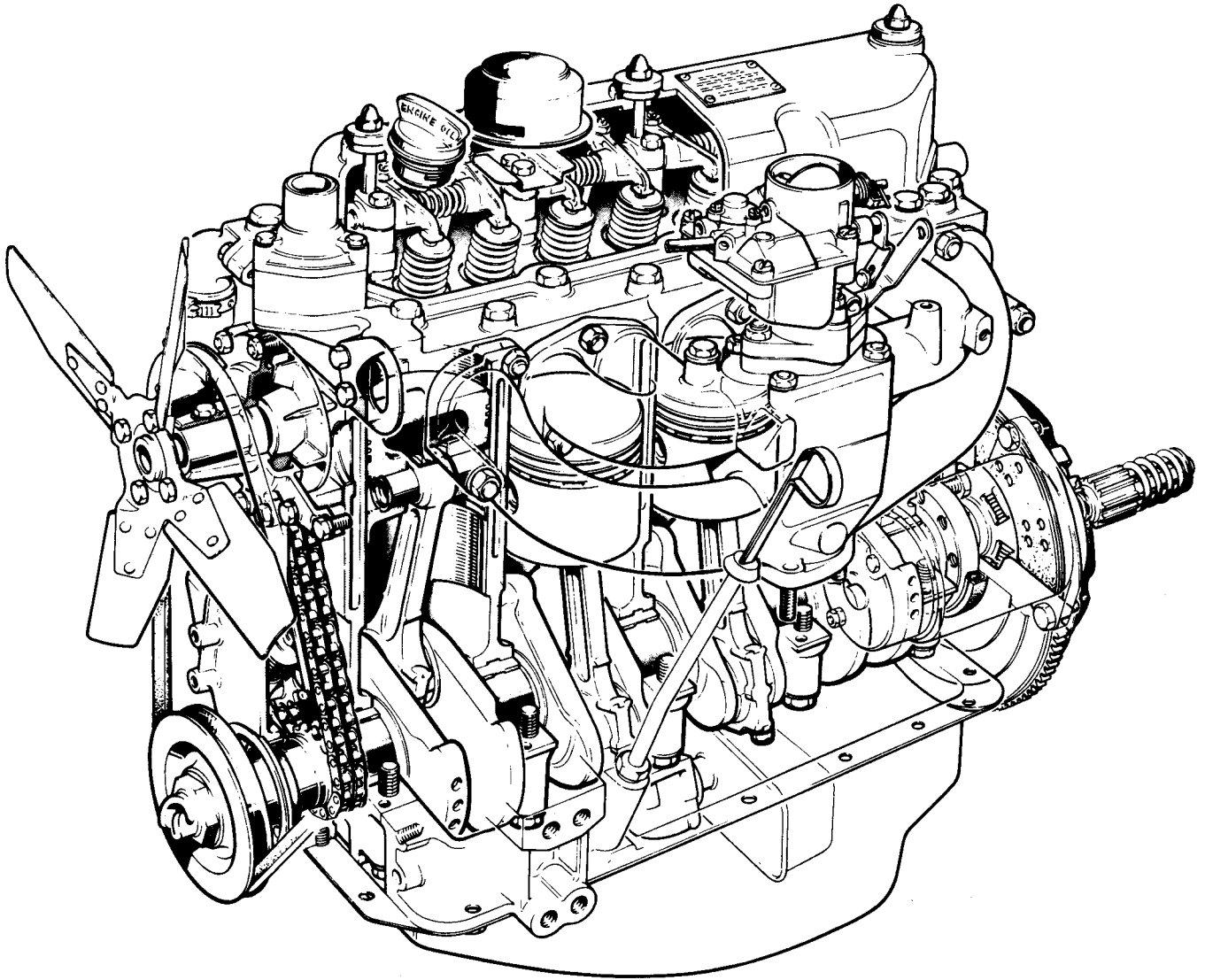

**Land Rover 2 1/4 litre five main bearing Petrol Engine**

## CRANKSHAFT REAR OIL SEAL

-Remove and refit

12.21.20

Service tool 18G1344 Seal guide

## Removing

1. Remove the engine from the vehicle leaving the gearbox in position in the chassis 12.41.01.
2. Remove the clutch assembly, instructions 4 to 7 33.10.01.
3. Remove the retaining bolts and withdraw the flywheel.
4. Remove the flywheel housing complete with rear main oil seal.
5. Remove and discard the flywheel housing 'O' ring.
6. Carefully remove and discard the oil seal.

## Refitting

**NOTE:** The satisfactory operation of the rear main oil seal in service depends upon the care and cleanliness exercised during the following instructions.

7. Check that the crankshaft oil seal journal is not damaged and is clean.
8. Make sure the seal housing is clean and dry and free from burrs.
9. Taking care not to touch the seal lip ensure that the outside diameter is clean and dry.
10. With the lip side leading, slowly press in the seal, square to the bore of the seal housing, until the seal is flush or a maximum of 0.50mm (0.020 in) below the outer face of the flywheel housing.
11. Fit the 'O' ring seal to the flywheel housing.
12. Examine the seal guide number 18G1344 and repair any damage that could destroy the seal lip.
13. Lubricate the outside diameter of the seal guide and the seal journal with concentrated "Oildag" in a 25% solution with clean engine oil.
14. Place the seal guide on the crankshaft flange and, using the two dowels, protruding from the cylinder block rear face, as a guide to ensure initial squareness, fit the flywheel housing and remove the seal guide.
15. Secure the flywheel housing evenly tightening the retaining bolts.
16. Fit the flywheel, following instructions 5 to 8 in operation 12.53.07 of this supplement.
17. Fit the clutch, instructions 8 and 9 33.10.01.
18. Smear the splines of the primary shaft, the clutch centre splines and the withdrawal unit abutment faces, with molybdenum disulphide grease, such as 'Rocol' MTS 1000.
19. Refit the engine.

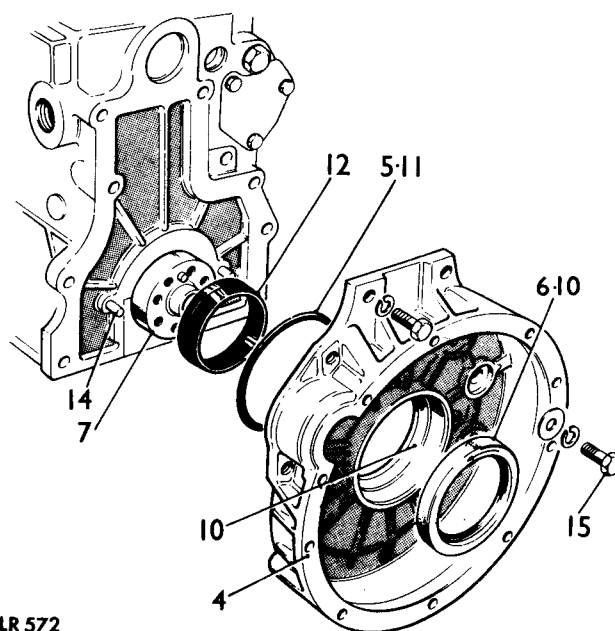
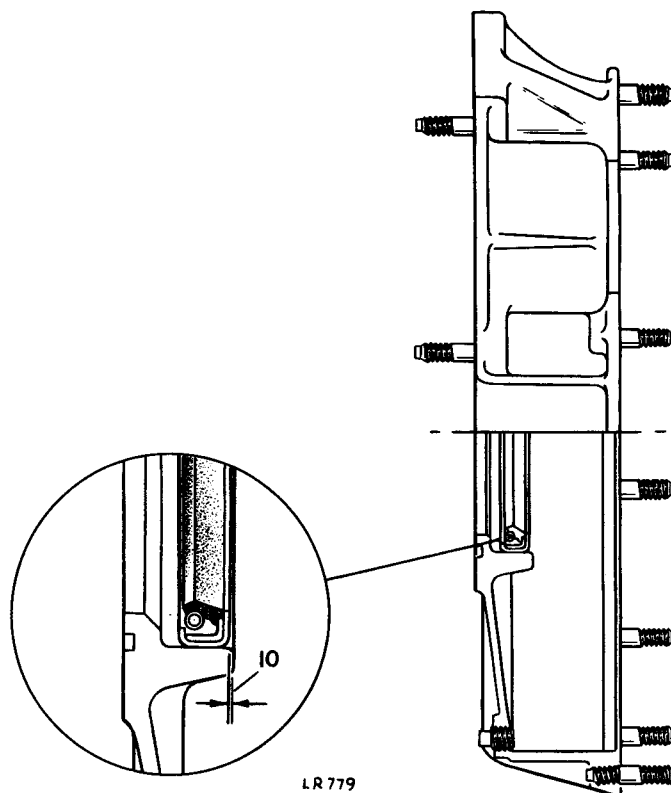

# ENGINE

## CRANKSHAFT

—Remove and refit

12.21.33

Special tools 270304 Cork seal guides  
530102 Starter dog spanner

### Removing

1. Remove the bonnet, 76.16.01.
2. Remove the air cleaner, 19.10.04.
3. Remove the radiator and front panel assembly complete.
4. Remove the front floor, 76.10.12.
5. Drain the oil sump.
6. Remove the engine assembly leaving the gearbox in position 12.41.01.
7. Remove the sump.
8. Remove the oil pump and strainer assembly complete with drive shaft.
9. Using a suitable piece of timber jam the crankshaft and remove the starter dog with special spanner 530102.
10. Remove the timing chain cover following instructions 3, 4, 7 and 8 to 13 operation 12.65.01.
11. Remove the timing chain tensioner.
12. Remove the timing chain from the sprockets.
13. Remove the clutch assembly.
14. Remove the flywheel.
15. Remove the flywheel housing complete with rear main oil seal and 'O' ring.
16. Remove the connecting rod caps and lower bearing shells and push the connecting rods clear of the crankpins taking care not to damage the pistons and valves.
17. Cover the connecting rod bolt threads with thin plastic or rubber sleeves to prevent damage to the crankpins.
18. Remove the five main bearing caps and lower shells.
19. Lift out the crankshaft.
20. If required, remove the chainwheel and key from the crankshaft.

### Refitting

**NOTE:** If replacement components are to be fitted the checks detailed in operation 12.21.46 must be carried out.

21. Locate the main bearing halves in the crankcase and lubricate with engine oil.
22. Check the crankshaft end-float which should be 0,05mm to 0,15mm (0.002 to 0.006in.) by following instructions 23 to 26.
23. Position a standard size thrust washer each side of the centre main bearing saddle with the unplated faces towards the cylinder block.

*Continued*

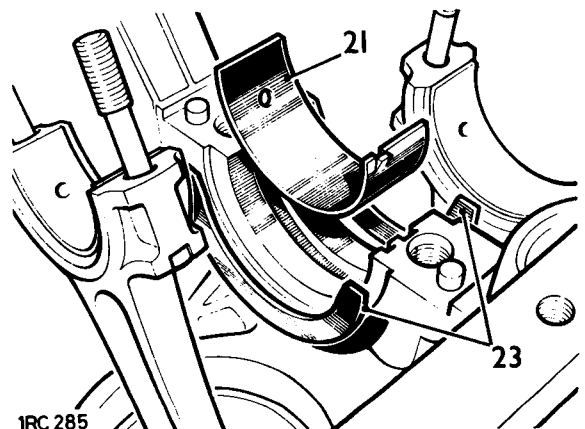

1RC 285

24. Rest the crankshaft in position in the crankcase.
25. Mount a dial test indicator to read-off the end of the crankshaft and check the end-float.
26. If adjustment is required, substitute with oversize thrust washers – see data to obtain the required end-float. The variation of thrust washer thickness at each side must not exceed 0,08mm (0.003in.) to ensure that the crankshaft remains centralised.
27. Locate the bearing halves in the main bearing caps and fit cap numbers 1 to 4 ensuring that they locate properly over the dowels. Loosely secure with new bolts.

**NOTE:** New bolts and washers must be fitted on petrol engine serial number range 36100001A, 99100001A and diesel engine range 36600001A. See note following instruction 32.

28. Ensure that number five main bearing cap is clean and free from old cork seal material.
29. Attach the cork seal guides number 270304 to the crankcase, as illustrated, and ensure that they are parallel to the crankcase edge.

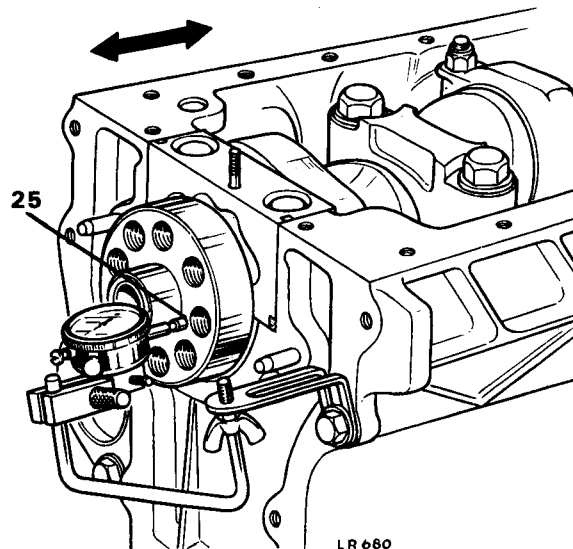

*Continued*

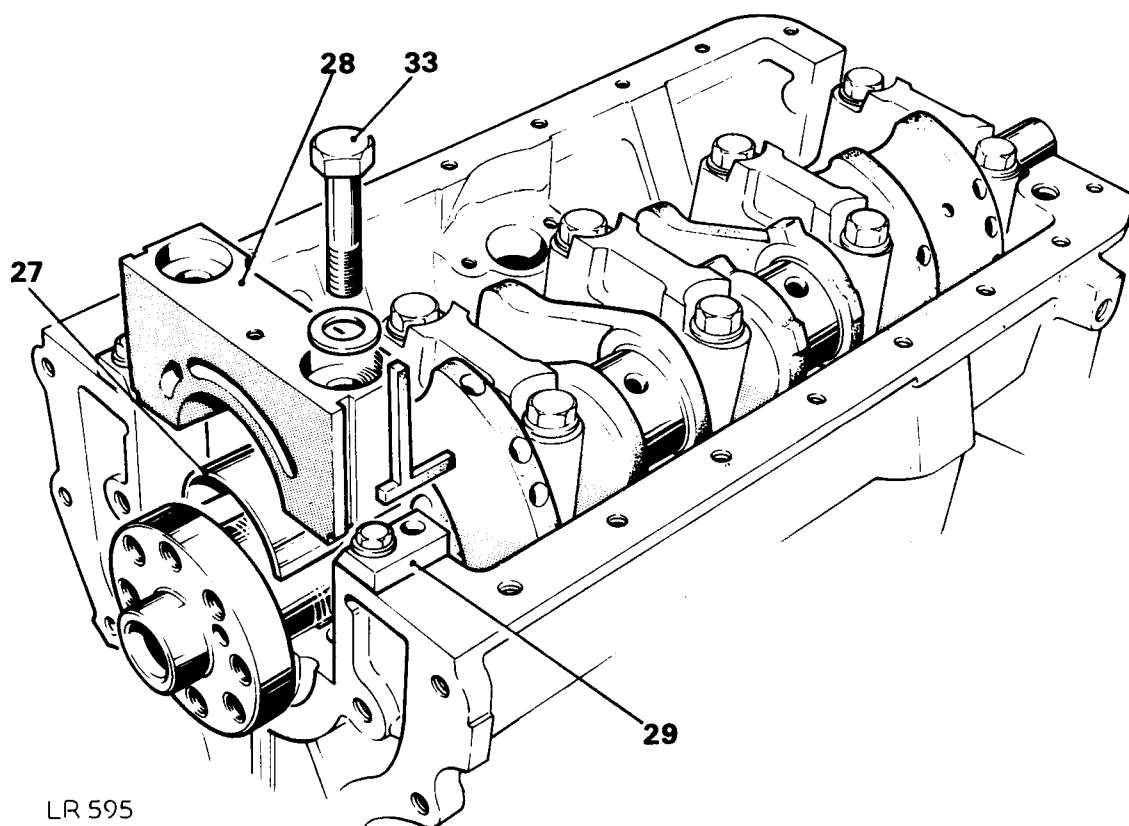

## ENGINE

30. To prevent any cork seal material becoming trapped between the bearing cap and crankcase, chamfer the inner edge of the corks 0,40 to 0,80mm (1/64 to 1/32in.) wide as illustrated.
31. Immerse the cork seals in engine oil and fit them to the bearing cap.
32. Fit the cap to the cylinder block and loosely secure with new bolts. See note following instruction 27 above.

**CAUTION:** Petrol engine serial number range commencing 99100001A employ plain washers and diesel engine specifications bolts. These bolts are not interchangeable with those on serial number range 36100001A, where spring washers are used.

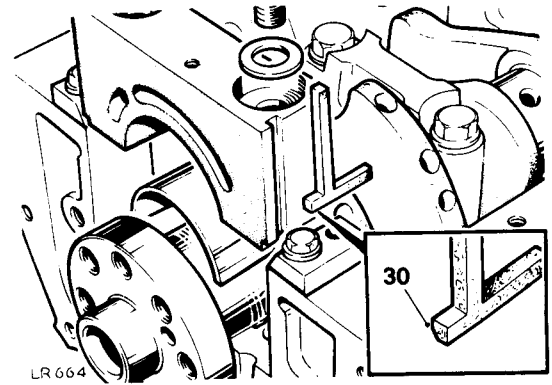

33. Commencing with the centre main bearing evenly tighten the bolts to 11,5kgf.m. (85lb.ft.) for engine serial number range 36100001A and 13 to 14kgf.m. (100lb.ft.) for serial range 99100001A and diesel engine range 36600001A.
34. To allow for shrinkage after fitting leave the cork seals standing proud of the crankcase-ump face. If possible delay the fitting of the sump for approximately twelve hours and leave the seal protruding 2,40mm (3/32in.) and then place a 6,350mm (1/4in.) washer over the seal and cut off the surplus. If it is necessary to fit the sump immediately, trim the seals off leaving 0,80mm (1/32in.) proud, that is, the thickness of the above washer.
35. Apply Hylomar SQ32M to the protruding end of the seals.
36. Fit the appropriate bearing halves and caps to the connecting rods using new nuts and tighten to 3,5 kgf.m. (25lb.ft.) for serial number range 36100001A and diesel engine range 36600001A. Tighten to 4,45kgf.m. (30 to 35lb.ft.) for serial number range 99100001A.

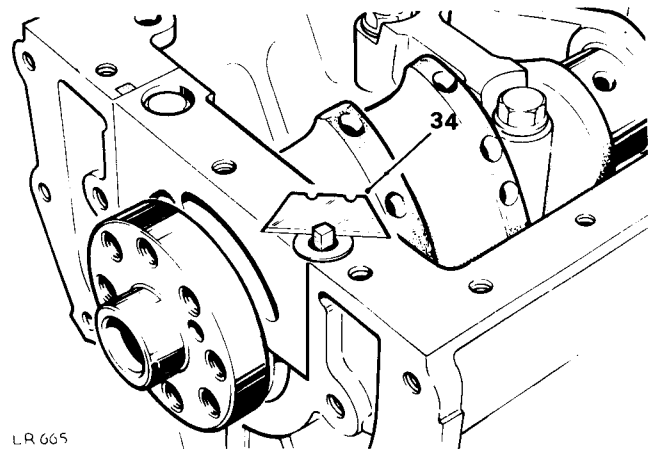

**CAUTION:** The connecting rod bolts have eccentric heads which locate in slots in the connecting rod. It is essential that the bolt heads are properly located before tightening.

37. Fit the rear main oil seal and housing instructions 7 to 14 operation 12.21.20 of this supplement.
38. Fit the flywheel following instructions 5 to 8 operation 12.53.07 of this supplement.
39. Smear the splines of the primary shaft, the clutch centre splines and the withdrawal abutment faces with Molybdenum disulphide grease such as Rocol MTS1000.
40. Fit the clutch assembly 33.10.01.
41. Fit the timing chain tensioner.

*Continued*

42. Fit the timing chain cover and starter dog. Operation 12.65.01.
43. Fit the oil pump.
44. Fit the sump.
45. Fit the engine.
46. Fill the sump to the high mark on the dipstick with new oil of the recommended make and grade in accordance with the territory and temperature conditions under which the vehicle is operating.
47. Reverse instructions 1 to 4 of this operation.

## DATA

### Crankshaft

Journal diameter	63,5mm – 0,012mm (2.5in. – 0.0005in.).
Crankpin diameter	58,7mm (2.312in.).
End-float (controlled by thrust washers at centre bearing)	0,05mm to 0,15mm (0.002 to 0.006in.).
Thrust washers for the crankshaft centre main journal, to control the crankshaft end float, are available in the following oversizes:	0,06mm (0.0025in.). 0,12mm (0.005in.). 0,18mm (0.0075in.). 0,25mm (0.010in.).

Regrind sizes: – Petrol Engines only:

Undersize	Journal dia.	Crankpin Dia.
0,25mm (0.010in.)	63,24mm (2.490in.)	58,47mm (2.302in.)
0,50mm (0.020in.)	62,99mm (2.480in.)	58,22mm (2.292in.)
0,76mm (0.300in.)	62,73mm (2.470in.)	57,96mm (2.282in.)
1,01mm (0.040in.)	62,48mm (2.460in.)	57,70mm (2.272in.)

Connecting rod bearing running clearance  
Main bearing running clearance

0,019mm to 0,063mm (0.0007in. to 0.0025in.).  
0,020mm to 0,055mm (0.0008in. to 0.0022in.).

## ENGINE

### FLYWHEEL

—Remove and refit

12.53.07

#### Removing

1. Remove the engine from the vehicle leaving the gearbox in position 12.41.01.
2. Remove the clutch assembly, instructions 4 to 7, 33.10.01.
3. Remove the eight retaining bolts and remove the reinforcing plate.
4. Withdraw the flywheel.

#### Inspection

5. Examine the flywheel pressure face for wear, cracks and scores. Provided that the width of the flywheel is not reduced beyond the following dimension it may be refaced if necessary.

Petrol engines	34,72mm (1.375in.)
Diesel engines	36,957mm (1.455in.)

#### Refitting

6. Clean the crankshaft and flywheel mating faces. Remove burrs and repair damage that could cause the flywheel to run-out. Ensure that the dowel fits correctly in the flywheel and crankshaft flange.
7. Fit the flywheel and reinforcing plate to the crankshaft and tighten the retaining bolts to 13,8kgf.m. (100lbf.ft.).
8. Mount a dial test indicator to the flywheel housing so that the stylus rests in a loaded condition on the pressure face at a radius of 114mm (4.5in.). Check the runout which must not exceed 0,05mm (0.002in.).
9. If the run-out is excessive repeat instruction 6. If the cause of the run-out cannot be found renew the flywheel.
10. Fit the clutch, instructions 8 and 9, 33.10.01.
11. Smear the splines of the primary shaft, the clutch centre splines and the withdrawal unit abutment faces with Molybdenum disulphide grease such as 'Rocol MTS 1000'.
12. Refit the engine to the vehicle.

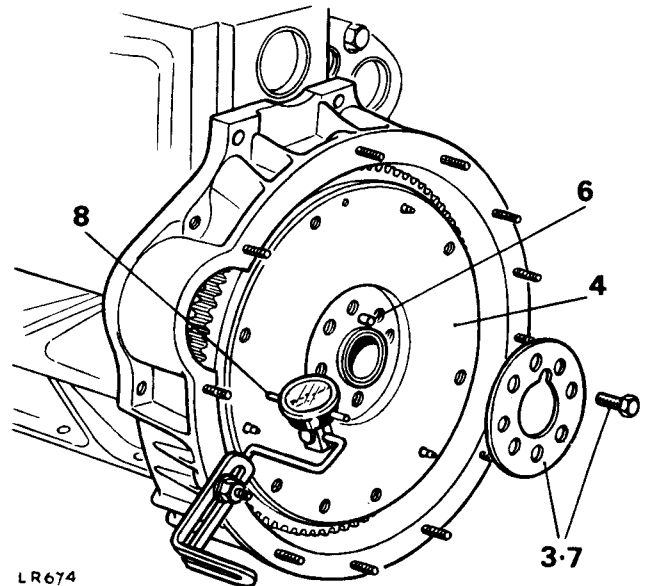



# **FUEL SYSTEM**

# **OPERATIONS**

# FUEL SYSTEM

## FUEL INJECTION PUMP

—Remove and refit

19.30.07

Service tool Timing gauge MS67B

### Removing

1. Remove the bonnet panel 76.16.01.
2. Remove the air cleaner, 19.10.04.
3. Disconnect the battery earth lead.
4. Disconnect the engine stop cable.
5. Disconnect the stop lever return spring.
6. Remove the clevis pin and disconnect the accelerator cable.
7. Remove the fuel pipes, distributor pump to injectors.
8. Disconnect the inlet and outlet fuel pipes from the distributor.
9. Remove the distributor pump fixings.
10. Withdraw the distributor pump.
11. Withdraw the distributor pump drive shaft.

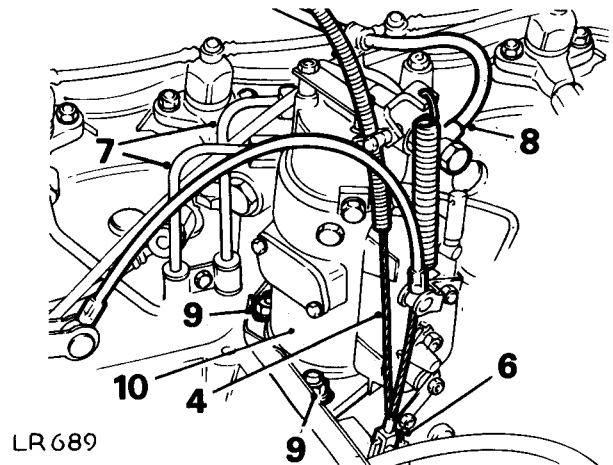

### Refitting and timing procedure

12. Remove the engine rocker cover.
13. Slacken the fixings and move aside the inspection cover on the flywheel housing to expose the timing pointer adjacent to the flywheel.
14. Turn the crankshaft in the direction of rotation until both valves of number one cylinder are closed and the piston is ascending the bore on the compression stroke.
15. Continue to turn the crankshaft until the timing pointer aligns with the 13° mark on the flywheel, that is 13° BTDC. This must be done carefully. If the flywheel is inadvertently turned too far and the timing mark goes past the pointer, do not turn the flywheel back, but repeat the operation.  
Ensure that a correct line of vision is taken when lining up the timing marks. An incorrect line of vision can result in the timing being 1° to 2° out.
16. The master spline on the driving gear should now be approximately 20° from the centre line of engine measured from the front end, that is, at the 4 o'clock position.

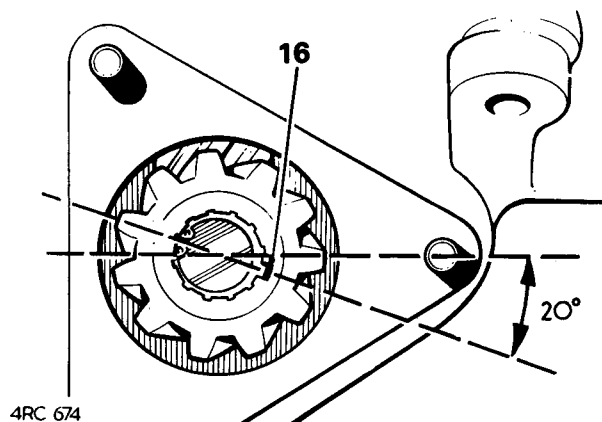
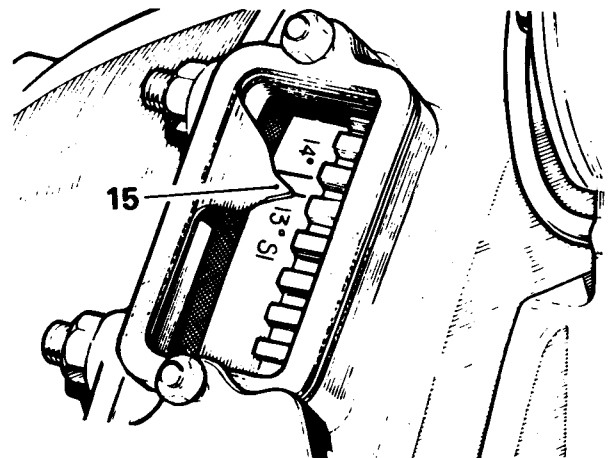

*Continued*

17. Using Service tool MS67B, assemble the scribing arm of the tool to the tool body.
18. Set gauge by loosening knurled screws and sliding bracket around until chamfered edge aligns with the required angle of 22°, tighten knurled screw in this position.
19. Insert tool MS67B into vacant injection pump position and engage tool gear into injection pump drive splines.
20. Release centre shaft retaining screw and slide tool body along centre shaft until body engages injection pump drive gear hub. Lock shaft retaining screw.
21. Apply gentle clockwise pressure to take up backlash or wear in gears, retain in this position.
22. Slacken off timing pointer bolts. Adjust timing pointer so that it aligns with scribing arm on tool. Tighten timing pointer bolts.
23. Remove tool MS67B.
24. Rotate driving gear on distributor pump so that master spline lines up with master spline on driving gear.
25. Then offer pump to engine, ensuring that the timing mark on the pump flange coincides with the timing pointer.
26. Tighten the injection pump retaining nuts.

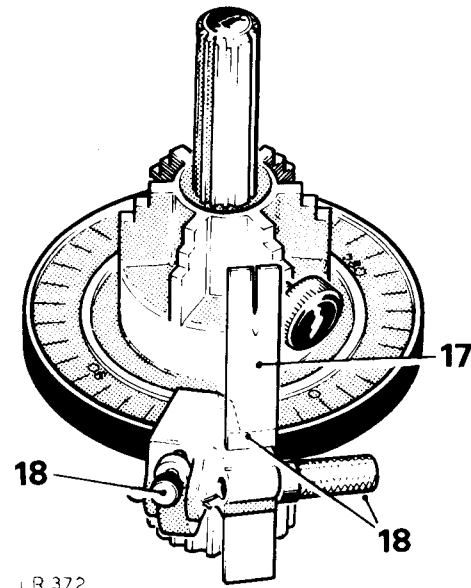

**NOTE:** When the distributor pump is timed as detailed above, that is, with the timing pointer on the engine altered to take up backlash and wear on the gears, it ensures that optimum distributor pump timing is achieved.

Should there be any fall-off of power during the life of the engine, retiming the distributor pump to take up gear wear could well make a significant improvement to engine performance, provided the engine is generally in good condition.

27. Reverse instructions 3 to 8 and 12 to 13.
28. Prime the fuel system 19.50.01.

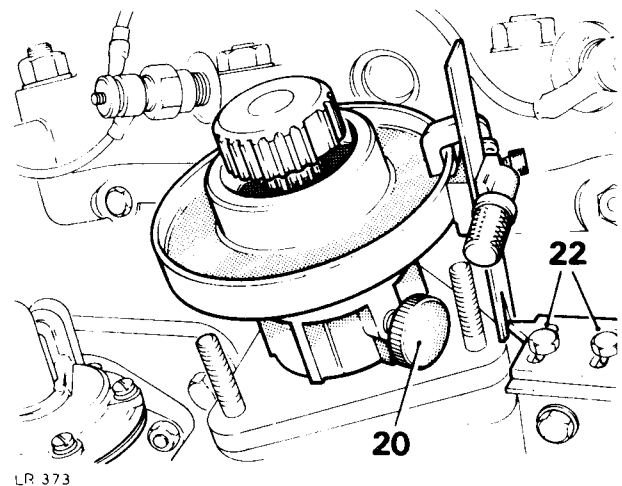

#### Setting the distributor pump control screws

29. On distributor pumps with the maximum output control screw sealed, the control screw setting must not be altered. Adjustment is allowed to the slow running control screw only.  
However, when a new or reconditioned distributor pump is to be fitted, it will be found that the slow running control screw is loosely attached to the distributor pump and that the maximum output control screw is not sealed.
30. It is necessary, therefore, after the distributor pump has been assembled to the engine, first to fit the slow running control screw and then adjust both screws as detailed in items 31 to 36.

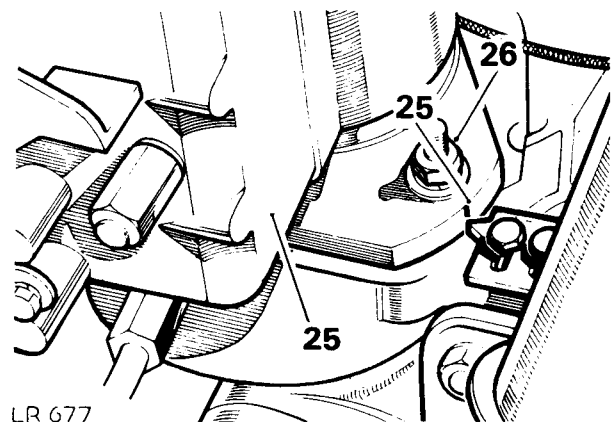

*Continued*

## FUEL SYSTEM

### Slow running control screw adjusting

31. Adjust the control screw until the engine slow running speed is  $590 \pm 20$  rev/min. This may be checked using a suitable revolution counter, or by adjusting the control screw until the lowest engine speed consistent with smooth, even running is achieved.
32. To adjust the slow running control screw, proceed as follows:
  - a. Check engine speed with revolution counter.
  - b. Slacken adjusting screw locknut and screw inwards to increase speed and outwards to decrease.
  - c. When a slow running speed of  $590 \pm 20$  rev/min has been obtained, tighten locknut.
  - d. Remove revolution counter.

### Maximum output control screw adjusting

33. Adjust the control screw, where necessary, until the engine maximum speed is  $4200 \pm 20$  rev/min. This may be checked using a suitable revolution counter, or by road test; the road speed equivalent of 4,200 rev/min being 48 mph (77 kph) in third gear.
34. When maximum engine speed of  $4,200 \pm 20$  rev/min has been obtained, tighten locknut.
35. Fit the adjusting screw collar.
36. Wire lock and seal the screw collar.
37. Reverse instructions 1 and 2.

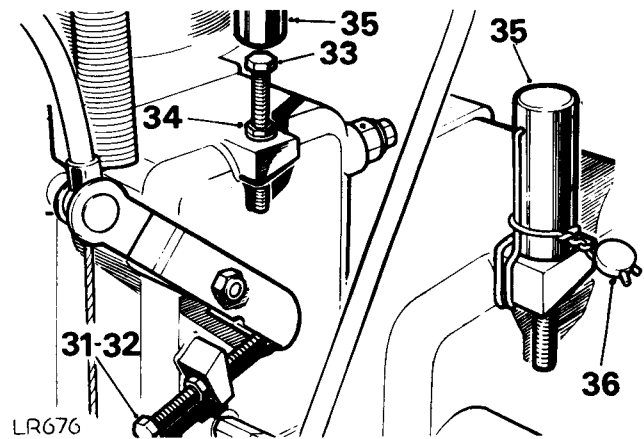

## FUEL INJECTION PUMP

### Altitude compensation for fuel injection pump

When vehicles equipped with diesel engines are operated at high altitude it is recognised that the reduced air density causes a reduction in the weight of air drawn into the engine cylinders, which results in incomplete combustion of the injected fuel at full throttle, unless this is reduced in proportion to the reduction in air density.

To compensate for these variations and to avoid excessive fuel consumption, accompanied by excessive exhaust smoke, the amount of fuel delivered to the cylinders must be reduced to suit the conditions under which the engine is required to operate, by de-rating the fuel pump delivery at a value of 3% per 330 metres (1,000 feet) of altitude operation.

It is recommended that vehicles intended for operation in high altitudes should have the injection pump adjusted by a C.A.V. dealer.

## DATA

Injection timing setting  
Idle speed  
Maximum speed setting (sealed)

$13^\circ$  BTDC  
 $590 \pm 20$  rev/min  
 $4,200 \pm 20$  rev/min

**ELECTRICAL**

**OPERATIONS**

## CONTACT BREAKER POINTS (Ducellier)

-Remove and refit

86.35.13

## Special tool 18G1308

## Removing

1. Release the spring clips and remove the distributor cap.
2. Pull off the rotor arm.
3. Remove the dust shield.
4. Remove the retaining screw and remove the fixed contact point.
5. Slide the spring clip rearwards.
6. Disconnect the suppressor lead from the connector block.
7. Disconnect the lead from ignition coil.
8. Remove insulation washer from the moving contact point.
9. Lift off the moving contact point complete with leads and connector block from the distributor body.

## Refitting

10. Fit the new moving point over post.
11. Locate the leaf spring in the plastic guide.
12. Fit the insulation washer.
13. Secure the assembly with the spring clip.
14. Fit the connector block to the distributor body.
15. Connect ignition coil lead.
16. Fit suppressor lead to connector block.
17. Fit the fixed contact point and loosely retain with the screw.

**NOTE:** The following two instructions describe the adjustment of the contact points. The accompanying illustration shows it being done with the aid of special tool 18G1308. Whilst the points can be adjusted to the datum setting only (see data) without the tool full distributor adjustment, i.e. dwell angle, dwell variation and vacuum advance can only be achieved by using this tool in conjunction with engine diagnostic equipment. It is essential that the above adjustments are carried out in order to maintain correct emission levels and maximum engine efficiency.

18. Rotate the engine until a cam of the rotor fully opens the points.
19. Using a feeler, adjust the position of the fixed contact point to the datum setting and tighten the retaining screw.
20. Check and adjust the dwell angle, dwell variation and vacuum advance, see instructions 38 to 43 operation 86.35.26.

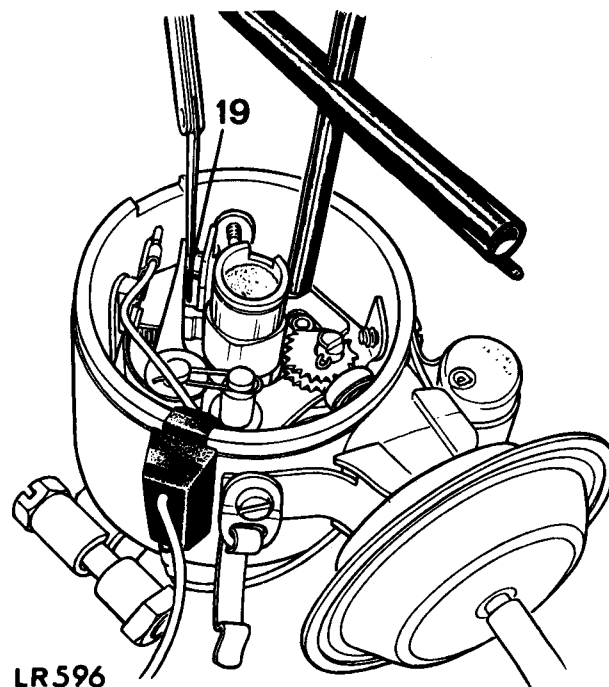
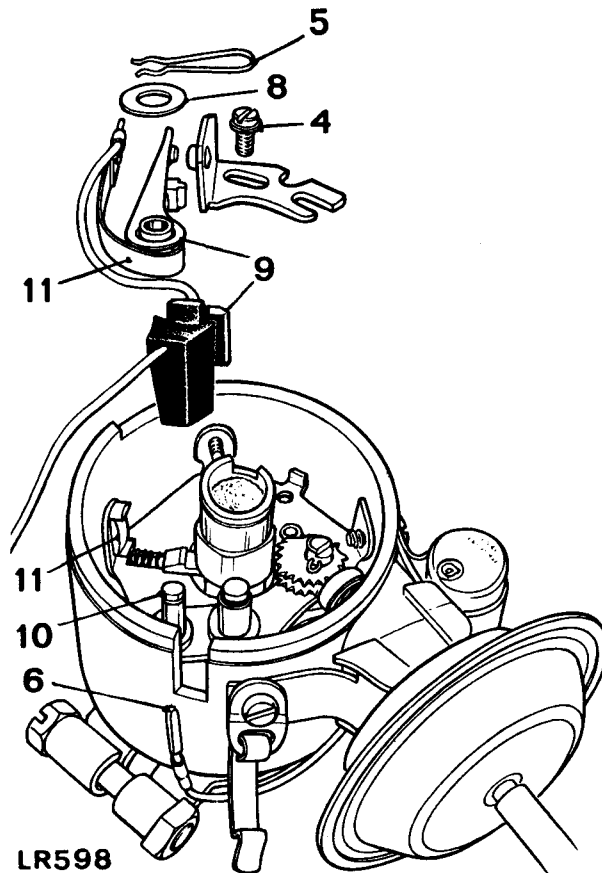

## CONTACT BREAKER POINTS (Lucas Sliding Contact)

-Remove and refit

86.35.13

## Removing

**NOTE:** The contact set should be renewed every 40,000km (25,000 miles).

1. Remove the distributor cap.
2. Remove the rotor arm.
3. Remove the retaining screw and lift the contact set complete from the plate.
4. Press the contact set spring and release the terminal plate and leads from the spring.

## Refitting

5. Clean the points with petrol to remove the protective coating.
6. Press the contact spring and fit the terminal plate with the black lead uppermost.
7. Fit the contact set to the moving plate, ensuring that the peg, underneath the contact pivot, locates in the hole in the moving plate.
8. The sliding contact actuating fork must also locate over the fixed peg.
9. Loosely secure the assembly with the screw, plain and spring washer.
10. Check that the contact leaf spring locates properly in the insulation shoe.

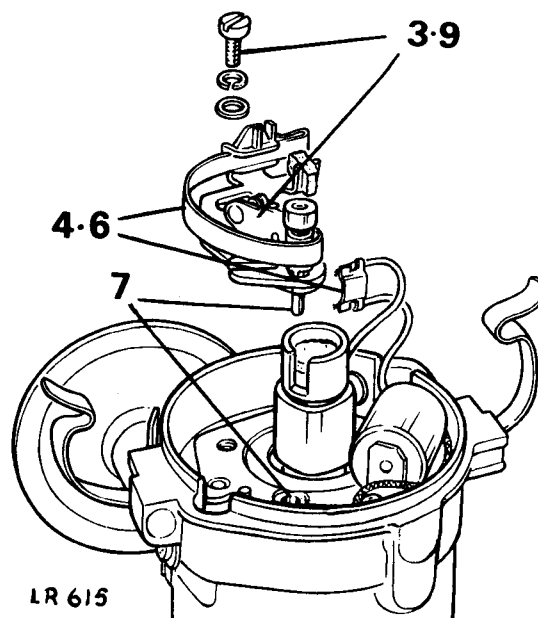

LR 615

## Adjusting the points gap

11. Rotate the crankshaft with the starting handle until the contact heel is on the highest point of a cam.
12. Adjust the gap by inserting a screwdriver blade between the 'V' shaped notch and pip and twist the screwdriver.
13. Insert a 0,35 to 0,40mm (0.014 to 0.016in.) feeler gauge between the points and adjust to a sliding fit and tighten the retaining screw.
14. Fit the rotor arm.

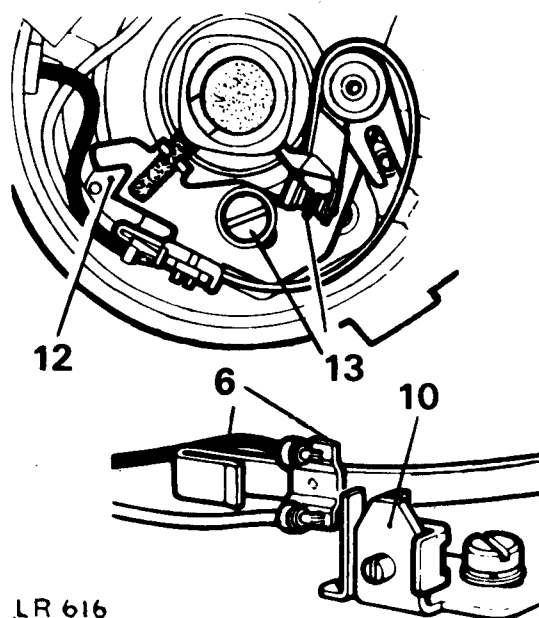

LR 616

*Continued*

## Lubrication

**NOTE:** The following instructions should be carried out every 20,000km (12,000 miles) except instruction 20.

15. Clean and lightly grease the cam with Shell Retinax or equivalent and remove any surplus lubricant.
16. Using the same grease lubricate the underside of the heel actuator.
17. Grease the actuator ramps and contact breaker heel ribs.
18. Apply grease to the fixed pin and the actuator fork.
19. Apply a drop of clean engine oil to the felt pad underneath the rotor arm.
20. Every 40,000km (25,000 miles) lubricate the automatic advance mechanism by injecting one or two drops of engine oil through the aperture in the base plate.
21. Wipe the internal and external surfaces of the distributor cap with clean dry nap-free cloth and fit the cap to the distributor body.

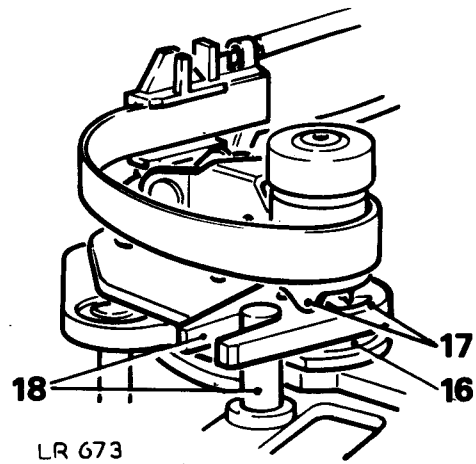
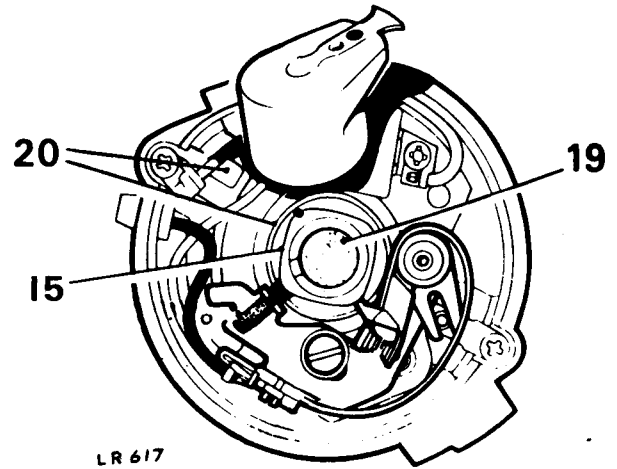



## DISTRIBUTOR (Ducellier)

-Overhaul

86.35.26

## Special tool 18G1308

## Dismantling

1. Remove the distributor from the engine 86.35.20.
2. Remove the distributor cap.
3. Remove the rotor arm.
4. Remove the dust cover.
5. Remove the felt pad from the top of the rotor.
6. Remove the two screws retaining the condenser and vacuum unit and remove the condenser lead from the connector block.
7. Remove the retaining clip from the eccentric 'D' post.
8. Mark the position of the serrated cam in relation to the spring seat of the vacuum operating link.
9. Disengage the vacuum operating link and serrated cam from the eccentric 'D' post and remove the vacuum unit.
10. Remove the retaining screw and withdraw the fixed contact plate.
11. Remove the retaining clip and insulation washer.
12. Release the connector block from the distributor body.
13. Lift out the moving contact complete with connector block and leads.
14. Mark the relationship of the base plate to the body and remove the retaining screw. Whilst holding the pressure pad clear of the rotor, withdraw the base plate.
15. Remove the moving contact post-plate.

## Inspection

**NOTE:** The distributor drive dog is loosely retained on the drive shaft, the "float" allows for any misalignment.

16. Examine the advance mechanism of the cam, check the shaft for excessive side play. If any of these parts are damaged or worn renew the complete distributor.
17. Examine all other components for damage or excessive wear and renew where necessary.
18. Check the distributor cover for signs of tracking or cracks and check that the pick-up brush moves freely in its holder.
19. Check the rotor arm for damage, electrode security, burning and tracking.

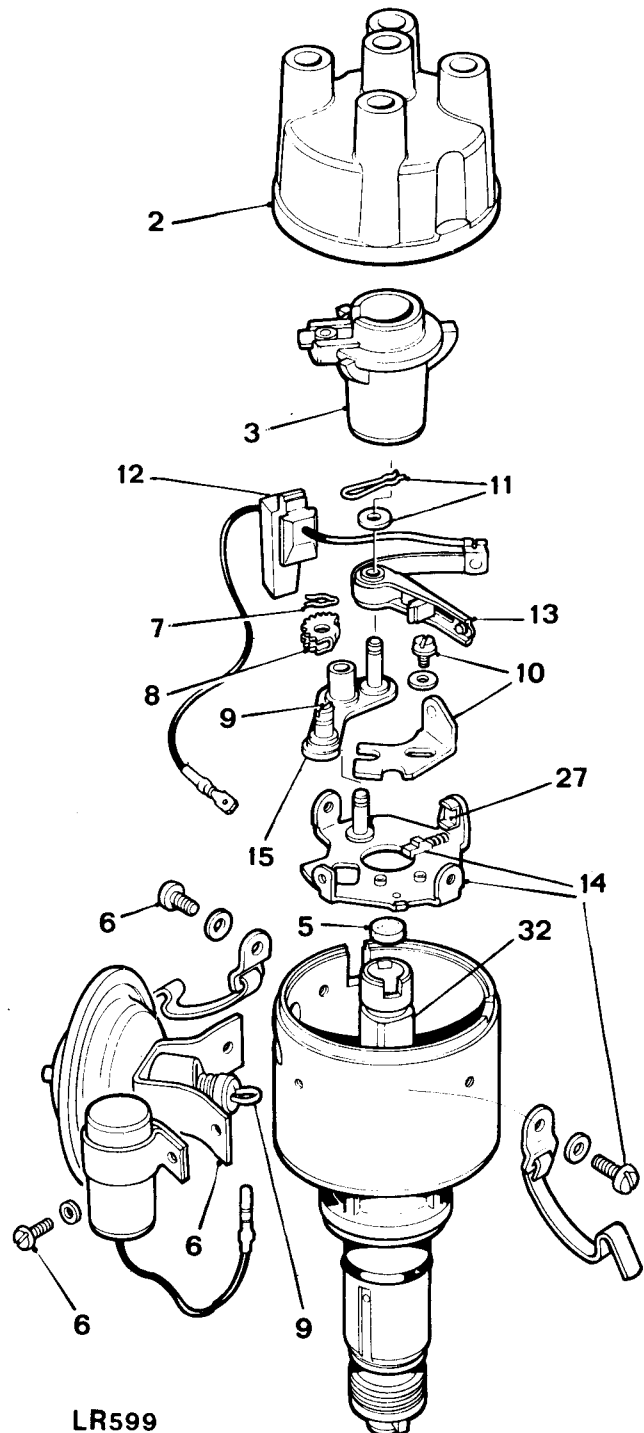
*Continued*

Reassembling

20. Using Retinax 'A' or equivalent grease lubricate the centrifugal weight pivot posts and lightly smear the cam pressure pad and contact pivot post.
21. Fit the pressure pad and spring to the base plate.
22. Fit the base plate to the body, lining up the marks, and secure with the retaining screw and clip on the opposite side to the vacuum unit.
23. Smear a little grease on the post and fit the moving contact post-plate to the base plate.
24. Offer up the vacuum unit to the body and fit the operating link and serrated cam to the 'D' post. Ensure that the identification marks line up – see instruction 8. Secure the assembly with the spring clip.
25. Secure the vacuum unit and condenser to the body with the remaining screw and clip.
26. Fit the fixed contact and loosely retain with the screw.
27. Fit the moving contact ensuring that the leaf spring locates in the nylon guide.
28. Fit the connector block to the body.
29. Fit the insulation washer and retain assembly with the spring clip.
30. Fit condenser lead to connector block.
31. Place the felt pad in the top of the rotor and add a few drops of oil.
32. Smear a small quantity of grease on the rotor cam.
33. Adjust the contact point gap to a datum setting of 0,43mm (0.017in.) with a feeler gauge by turning the rotor spindle until a cam fully opens the points. Move the fixed contact plate to obtain the required gap and tighten the retaining screw.
34. Fit the distributor to the engine, see operation 86.35.20.
35. Fit the dust cover.
36. Fit the rotor arm and distributor cap.
37. Connect the H.T. leads to the appropriate spark plugs.

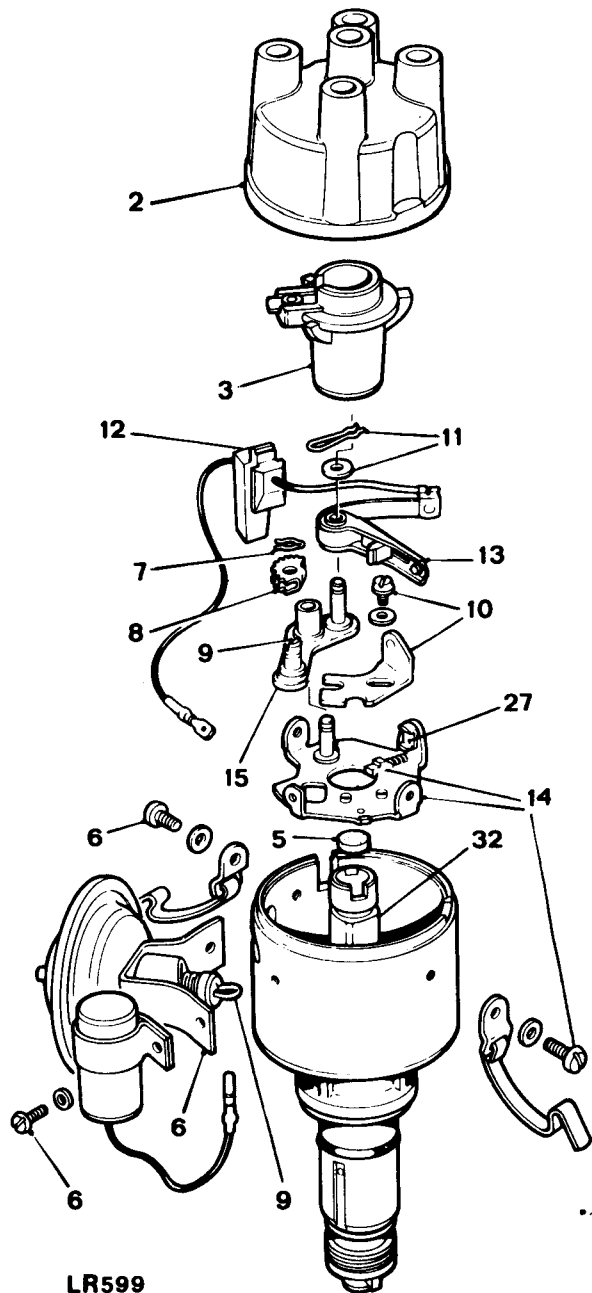

LR599

*Continued*

**Check and adjust dwell angle**

**NOTE:** The following six instructions can only be carried out using engine diagnostic equipment and special tool 18G1308.

38. Start the engine, disconnect the vacuum pipe from the vacuum unit and with the engine idling check the dwell angle – see data. If adjustment is required stop the engine, remove the distributor cap, rotor arm and dust cover, slacken the fixed contact retaining screw and using the eccentric-post end of the special tool, as illustrated, make an appropriate adjustment. Tighten the retaining screw, reassemble the distributor and recheck the dwell angle.

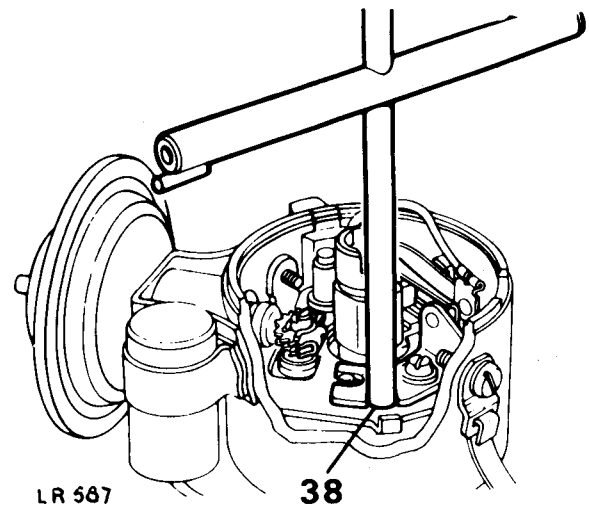
**Check and adjust dwell variation**

**NOTE:** A dwell variation outside the accepted tolerance – see data can be caused by a mechanical fault or wear within the distributor. This may be checked as follows:

39. Disconnect the vacuum advance, start the engine and increase the speed to 2000 r.p.m. A variation outside the tolerance given in data indicates that the distributor has a mechanical fault which cannot be rectified by adjustment.
40. If the variation is acceptable, reconnect the vacuum pipe, start the engine and increase the engine speed to 2,000 rpm and release the throttle. Check the dwell variation and if necessary adjust by turning the eccentric 'D' post with the special tool (female 'D' end). Setting the dwell for minimum variation may alter the basic setting and this must be rechecked at idle speed.

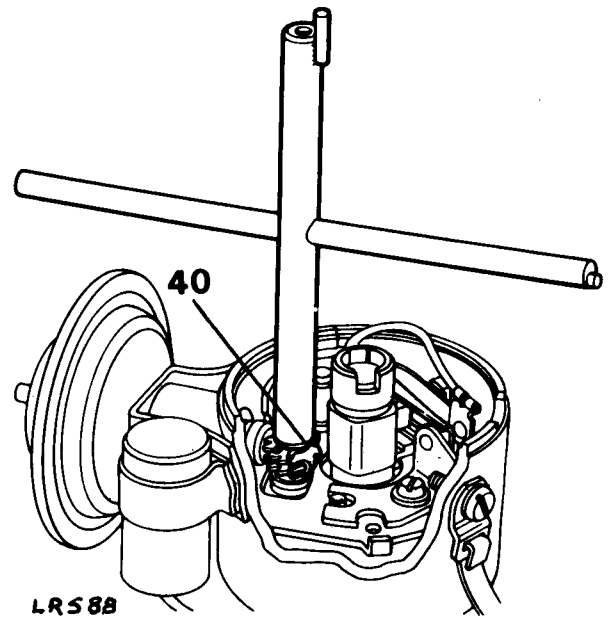
**Check the vacuum advance**

**NOTE:** If the vacuum unit has been removed or the distributor dismantled, the vacuum advance must be checked and if necessary adjusted.

41. Disconnect the vacuum pipe and connect a vacuum pump to the unit.
42. Start and run the engine at idle speed and using a timing light, slowly increase the vacuum and note the point at which vacuum advance starts and compare the figure with that given in data.
43. Adjustment of the serrated cam, with the special tool, one tooth at a time, will alter the point at which vacuum advance starts.

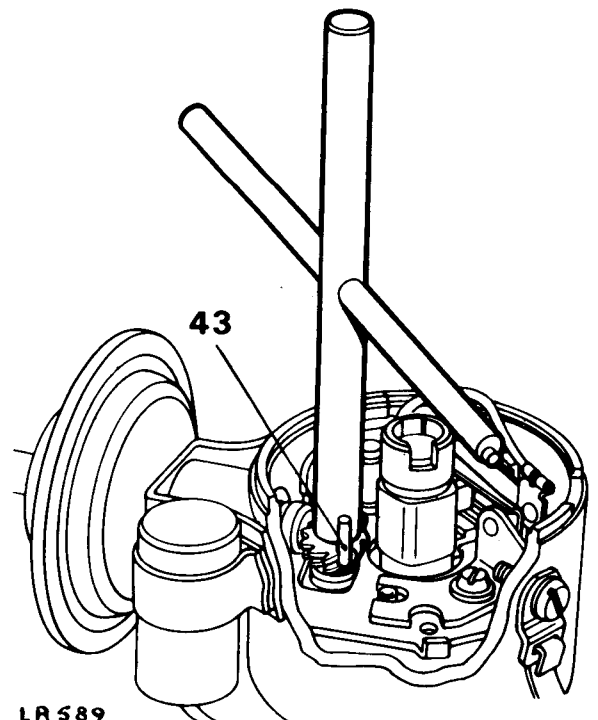

*Continued*

## ELECTRICAL

---

### DATA

Rotation	Anti-clockwise at rotor end
Contact points gap (datum figure only)	0,43mm (0.017in.)
Dwell angle	57°
Dwell variation	± 2° 30'
Vacuum advance starts	102mm (4in.) HG
Vacuum advance max.	12° at 457mm (18in.) HG
No centrifugal advance below	900 rev/min